

LINED VALVE COMPANY, INC.

FIGURE 193 BONNETED KNIFE GATE VALVE



FEATURES



- Bonneted Knife Gate Valves are ideally suited to aid in reduction of **Fugitive Emissions** and **Packing Leakage**.
- **Bonnet Design Pressure** same as valve pressure rating - **150 psi**.
- **Cast stainless steel body**, gland and yoke.
- **Fabricated bonnet** which can be designed to the full pressure rating of the valve.
- **Wiper** between body and bonnet to prevent solids from entering bonnet.
- **TFE Lubricated Synthetic Packing (TLSP)** rated for 400° F with a pH rating of 3-11 is standard.
- **Heavy duty designed body** to resist deflection from line loads and internal pressure.
- Gate designed to withstand full 150 PSI rated pressure as required by MSS-SP-81.
- Body cavity, seat configuration and beveled gate designed to provide shut-off capability in thick media such as pulp stock, slurries, or with solid media such as pellets or powders.
- **Heavy duty cast stainless steel yoke** will not bend or twist under extreme loads.
- **Easy conversion** from handwheel operator to cylinder, bevel gear or electric motor operator using cast yoke.
- **Enclosed brass stem bushing** provides reduced operating torque and protection of the stem bushing from harsh environments.
- **Hard faced seat** available to prevent galling in high cycle and/or high end pressure applications or abrasive applications.
- **O-Ring resilient seat** available.
- **Precision machined** stainless steel gate for superior seating capability.
- **Stainless steel stem** for corrosion resistance.
- **Designed and tested to MSS-SP-81** dimensions and specifications.
- Full port ID.

LINED VALVE COMPANY, INC BONNETED KNIFE GATE VALVE—FIG 193

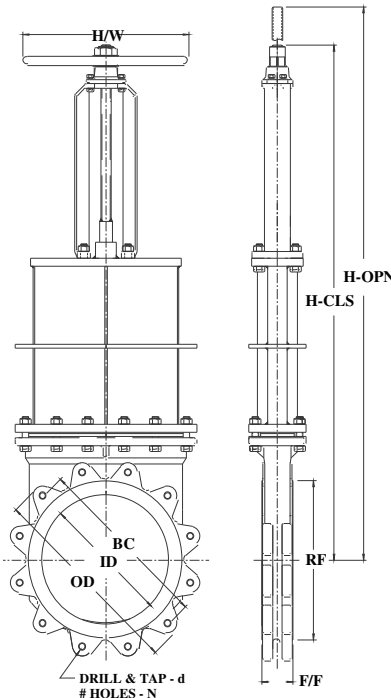
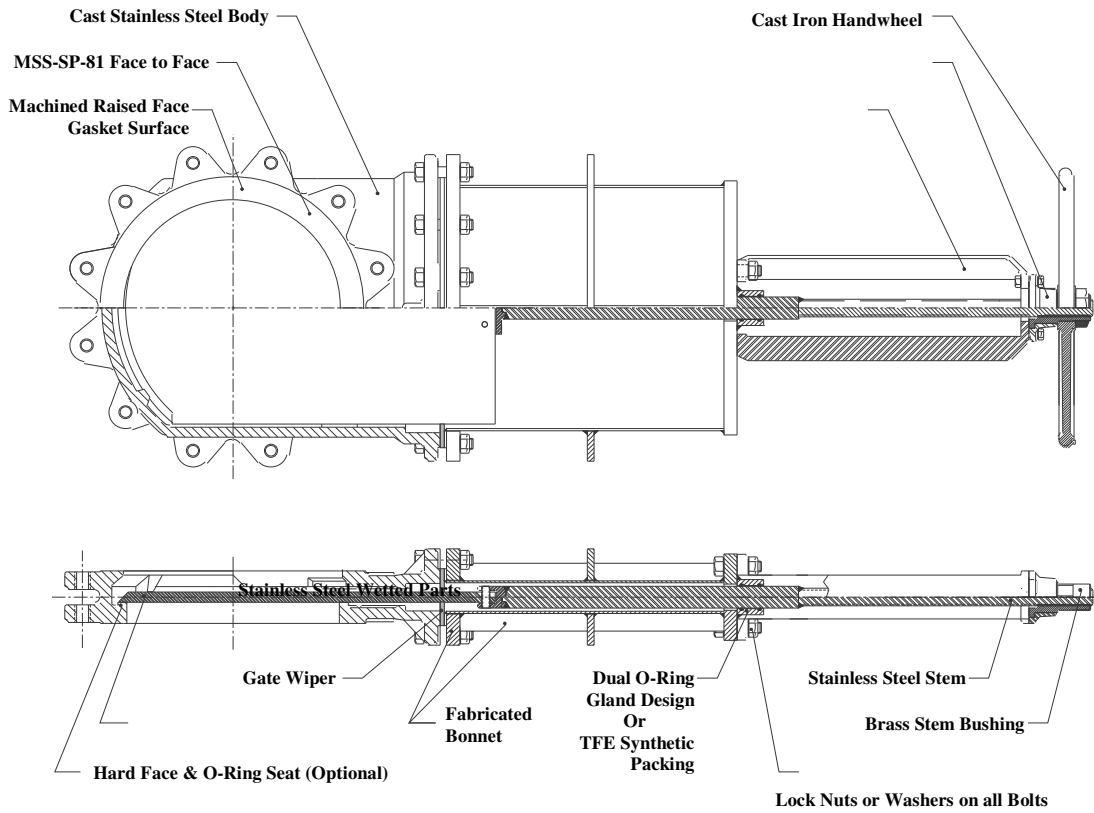

DIMENSIONS:

	VALVE SIZE										
	3"	4"	6"	8"	10"	12"	14"	16"	18"	20"	24"
ID	3"	4"	6"	8"	10"	12"	13-1/4"	15-1/4"	17-1/4"	19"	23"
F/F	2"	2"	2-1/4"	2-3/4"	2-3/4"	3"	3"	3-1/2"	3-1/2"	4-1/2"	4-1/2"
BC	6"	7-1/2"	9-1/2"	11-3/4"	14-1/4"	17"	18-3/4"	21-1/4"	22-3/4"	25"	29-1/2"
RF	5"	5-3/16"	8-1/2"	10-5/8"	12-3/4"	15"	16-1/4"	18-1/2"	21"	23"	27-1/4"
OD	7-1/2"	9"	11"	13-1/2"	16"	19"	21"	23-1/2"	25"	27-1/2"	32"
N	4	8	8	8	12	12	12	16	16	20	20
d	5/8"-11	5/8"-11	3/4"-10	3/4"-10	7/8"-9	7/8"-9	1"-8	1"-8	1-1/8"-7	1-1/8"-7	1-1/4"-7
H/W	8"	8"	12"	12"	16"	16"	20"	20"	20"	20"	20"
H-CLS	21-3/4"	24-1/2"	30-1/4"	36-1/2"	41-1/4"	48-3/4"	58"	64"	70-1/4"	74-1/2"	88-1/2"
H-OPN	25"	29"	38"	46"	51-3/4"	61-1/2"	72-1/4"	80-1/2"	88-1/4"	94-1/4"	112-1/4"
WEIGHT	64	75	109	160	251	295	335	470	740	990	1400

MATERIALS:

	MATERIAL CODE				
	W44	A44	W66	A66	A77
BODY, GATE & SEAT	304	304	316	316	317
BONNET LINER	304	304	316	316	317
BONNET FLG & STIFF	STEEL	304	STEEL	316	317
GLAND	304	304	316	316	317
YOKE & RETAINER	304	304	304	304	304
STEM & CLEVIS	304	304	316	316	316
STEM BUSHING	BRASS	BRASS	BRASS	BRASS	BRASS
BOLTING	PLATED	304	PLATED	304	304
PACKING	TFE/SYN	TFE/SYN	TFE/SYN	TFE/SYN	TFE