

LINED VALVE COMPANY, INC.

FIGURE 82 FABRICATED SLIDE GATE VALVE

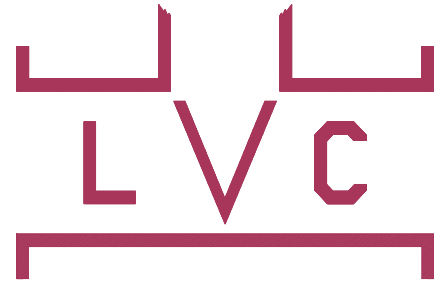

FEATURES



- **Fabricated** stainless steel lined body ideally suited for dense or abrasive media, both wet and dry.
- **Stainless steel** gate, seat and raised face.
- **Heavy duty** designed body to resist deflection from line loads and internal pressure.
- Gate designed to withstand full **150 PSI** rated pressure as required by **MSS-SP-81**.
- Body cavity, seat configuration and beveled gate **designed to provide shut-off** capability in thick media such as pulp stock, slurries, or with solid media such as pellets or powders.
- Valve **seat face is protected** by gate in both open and closed positions.
- **Full range of operators** available including air cylinder, bevel gear and electric motor operator.
- **Enclosed brass stem bushing** provides reduced operating torque and protection of the stem bushing from harsh environments.
- Can be manufactured in **special materials** such as ALLOY 20, HASTELLOY, TITANIUM and MONEL for severe services.
- O-Ring **resilient seat** available.
- **Precision machined** stainless steel gate for superior seating capability.
- **Stainless steel stem** for corrosion resistance.
- Teflon **wiper available** in packing to provide gate support and stabilize packing seal.
- **Designed and tested to MSS-SP-81** dimensions and specifications.
- **Hard face seat** available to prevent galling or wear

LINED VALVE COMPANY, INC. FABRICATED SLIDE GATE VALVE - FIG 82

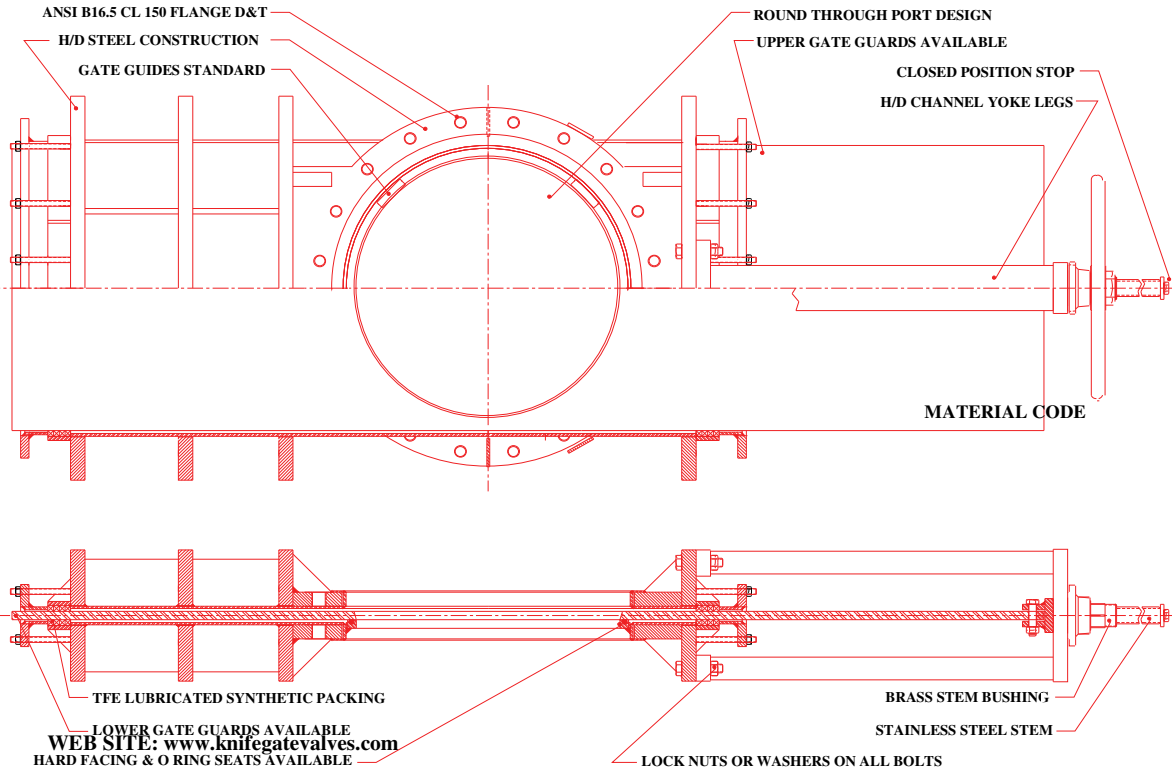

VALVE SHOWN IN OPEN POSITION

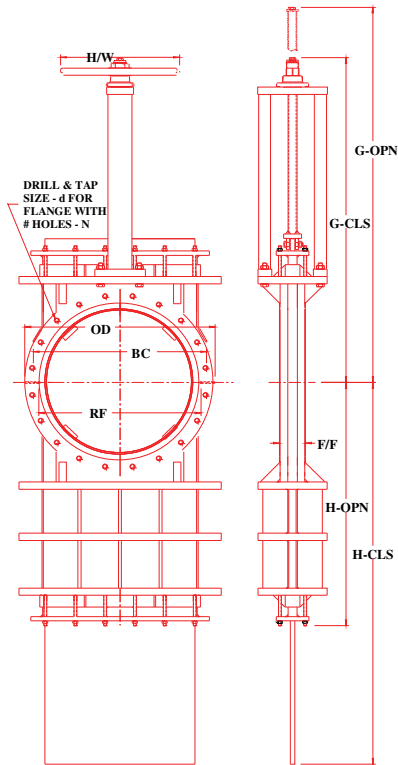

DIMENSIONS AND WEIGHTS:

	VALVE SIZE										
	3"	4"	6"	8"	10"	12"	14"	16"	18"	20"	24"
F/F	2"	2"	2-1/4"	2-3/4"	2-3/4"	3"	3"	3-1/2"	3-1/2"	4-1/2"	4-1/2"
BC	6"	7-1/2"	9-1/2"	11-3/4"	14-1/4"	17"	18-3/4"	21-1/4"	22-3/4"	25"	29-1/2"
RF	5"	6-3/16"	8-1/2"	10-5/8"	12-3/4"	15"	16-1/4"	18-1/2"	21"	23"	27-1/4"
OD	7-1/2"	9"	11"	13-1/2"	16"	19"	21"	23-1/2"	25"	27-1/2"	32"
N/d	4 5/8"-11	8 5/8"-11	8 3/4"-10	8 3/4"-10	12 7/8"-9	12 7/8"-9	12 1"-8	16 1"-8	16 1-1/8"-7	20 1-1/8"-7	20 1-1/4"-7
G-CLS	18-3/4"	20-1/2"	24-3/8"	28-1/2"	32-1/8"	36"	38-3/4"	42-1/2"	45-3/4"	47-1/2"	55-3/4"
G-OPN	22"	24"	31"	36"	43-5/8"	48-3/4"	51-1/2"	58"	63-3/4"	66-1/2"	79-3/8"
H-CLS	11-3/4"	14-1/2"	19-3/8"	24-1/2"	30-1/8"	36"	38-3/4"	44-1/2"	49-3/4"	54-1/4"	65-1/4"
H-OPN	9"	10"	13-1/4"	16-1/2"	19-5/8"	23-3/4"	24-3/4"	28-1/2"	31-3/4"	34"	41-1/2"
H/W	8"	8"	12"	12"	16"	16"	20"	20"	20"	20"	20"
Weight	75	92	122	170	245	340	445	565	640	915	1145

MATERIALS:

	W44	A44	W66	A66	A77
BODY, SEAT and RF	304	304	316	316	317
GATE	304	304	316	316	317
PACKING GLAND	STEEL	304	STEEL	316	317
FLANGES, EXT. TRIM	STEEL	304	STEEL	304	304
YOKE	STEEL	304	STEEL	304	304
STEM & CLEVIS	304	304	304	304	304
STEM BUSHING	BRASS	BRASS	BRASS	BRASS	BRASS
BOLTING	PLATED	304	PLATED	304	304
PACKING	TFE/SYN.	TFE/SYN.	TFE/SYN.	TFE/SYN.	TFE