

# LINED VALVE COMPANY, INC.

---

## FIGURE 93 STAINLESS STEEL METAL SEATED KNIFE GATE VALVE

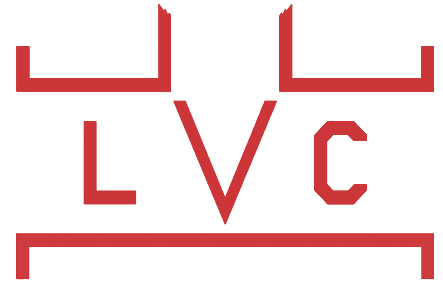

---

## FEATURES

---

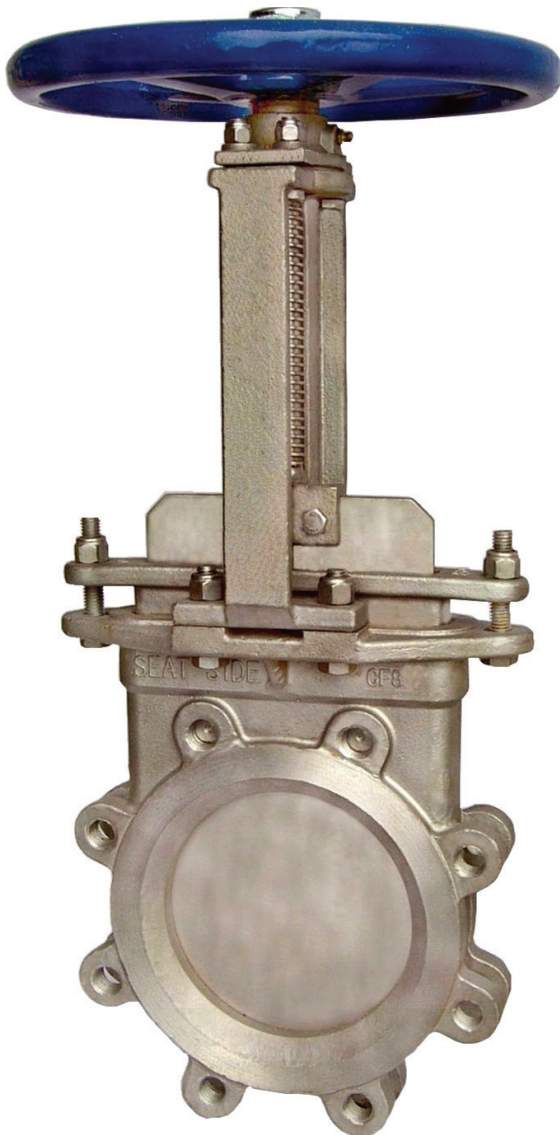

- **Cast stainless steel** body, gate, packing gland and yoke.
- **Heavy duty designed** body to resist deflection from line loads and internal pressure.
- Body cavity, seat configuration and beveled gate designed to provide shut-off capability in thick media such as pulp stock, slurries, or with solid media such as pellets or powders.
- **Heavy duty** cast stainless steel **yoke** will not bend or twist under extreme loads.
- **Easy conversion** from handwheel operator to cylinder, bevel gear or electric motor operator using cast yoke.
- **Enclosed brass stem bushing** provides reduced operating torque and protection of the stem bushing from harsh environments.
- **Hard faced seat** available to prevent galling in high cycle and/or high end pressure applications or abrasive applications.
- **O-Ring resilient seat** available.
- **Precision machined** stainless steel **gate** for superior seating capability.
- **Stainless steel stem** for corrosion resistance.
- Teflon wiper available in packing to provide gate support and stabilize packing seal.
- **Designed and tested to MSS-SP-81** dimensions and specifications.
- **Full port ID.**
- **TFE lubricated synthetic packing** (TLSP) rated for 400 F with a PH range of 3-11 is standard.

# LINED VALVE COMPANY, INC.

## CAST STAINLESS STEEL - METAL SEAT - KNIFE GATE VALVE

<b>MATERIALS OF CONSTRUCTION</b>	
<b>MODEL</b>	<b>76</b>
1 GATE	SS
2 BODY	SS
3 SEAT	SS
4 BOLTS	SS
5 PACKING	TLSP*
6 GLAND	SS
7 STEM	SS
8 YOKE	SS
9 STEM NUT	BRASS
10 HANDWHEEL	DI

\*TLSP = TFE Lubricated Synthetic Packing

Stocked in 304 and 316 SS. 317 SS Available.

Normally supplied with handwheel for manual operation, but can be modified for lever, chainwheel, bevel gear, electric, spring return cylinder, hydraulic cylinder or pneumatic cylinder operator.

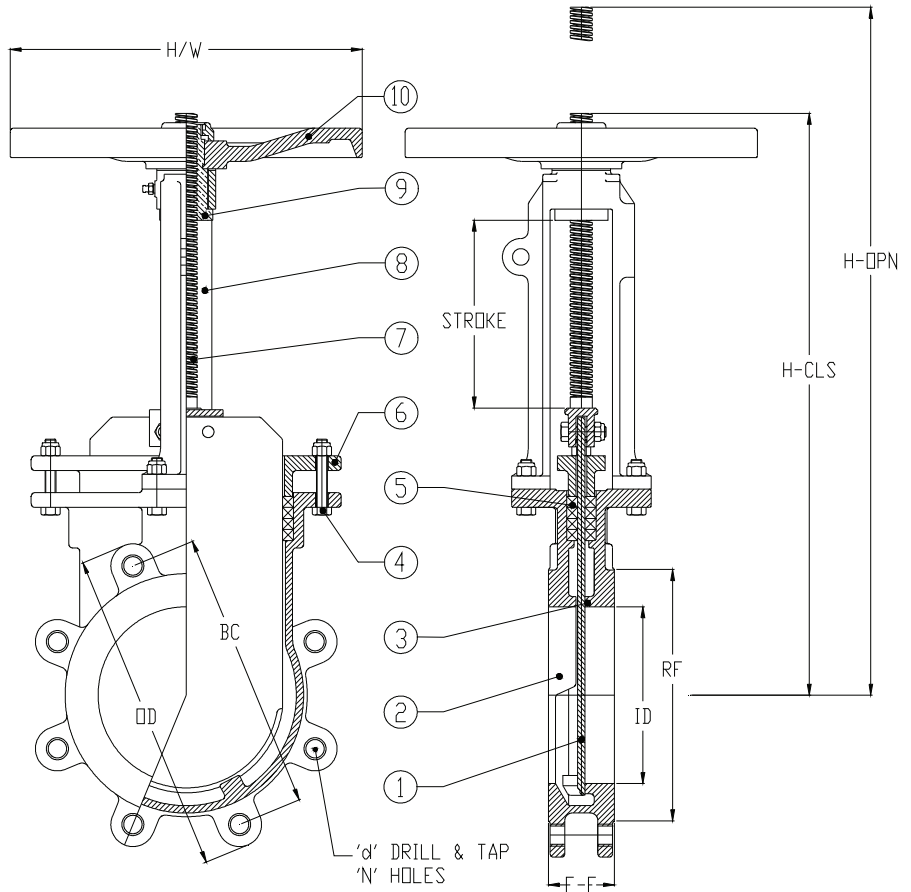

### DIMENSIONS (INCHES) AND WEIGHTS

SIZE		2"	3"	4"	6"	8"	10"	12"	14"	16"	18"	20"	24"
FACE TO FACE	F-F	1-7/8	2	2	2-1/4	2-3/4	2-3/4	3	3	3-1/2	3-1/2	4-1/2	4-1/2
FLANGE OD	OD	6	7-1/2	9	11	13-1/2	16	19	21	23-1/2	25	27-1/2	32
BOLT CIRCLE	BC	4-3/4	6	7-1/2	9-1/2	11-3/4	14-1/4	19	18-3/4	21-1/4	22-3/4	25	29-1/2
INSIDE DIAMETER	ID	2	3	4	6	8	10	12	13-5/8	15-1/2	17-1/2	19-1/2	23-3/8
NUMBER OF HOLES	N	4	4	8	8	8	12M	12	12	16	16	20	20
HOLE D&T SIZE	d	5/8	5/8	5/8	3/4	3/4	7/8	7/8	1	1	1-1/8	1-1/8	1-1/4
C/L TO TOP-CLOSED	H	12-5/8	14-1/2	16-1/2	19-3/4	24-1/4	29-1/2	33-1/8	37-1/2	42-1/2	47	51-3/4	58-1/4
C/L TO TOP-OPEN	H	14-7/8	17-3/4	20-5/8	26	32-3/4	39-5/8	45-1/2	51-1/8	58-3/8	64-1/2	71-1/2	82 1/4
HANDWHEEL DIA	H/W	8	8	8	12	12	15	15	15	20	20	20	30
WEIGHT - LBS.		20	29	38	52	85	120	160	250	300	403	495	666

Valve and Equipment Consultants Inc.  
24116 Yoakum St. Huffman Tx. 77336

281-324-1500  
[www.ValveAndEquipment.com](http://www.ValveAndEquipment.com)