

Resilient Seated Solid Wedge Gate Valve With Bevel Gear Operator - Series 6600

AWWA C509 & C515 ▪ NRS Type ▪ FL x MJ ▪ Sizes 18" - 24"

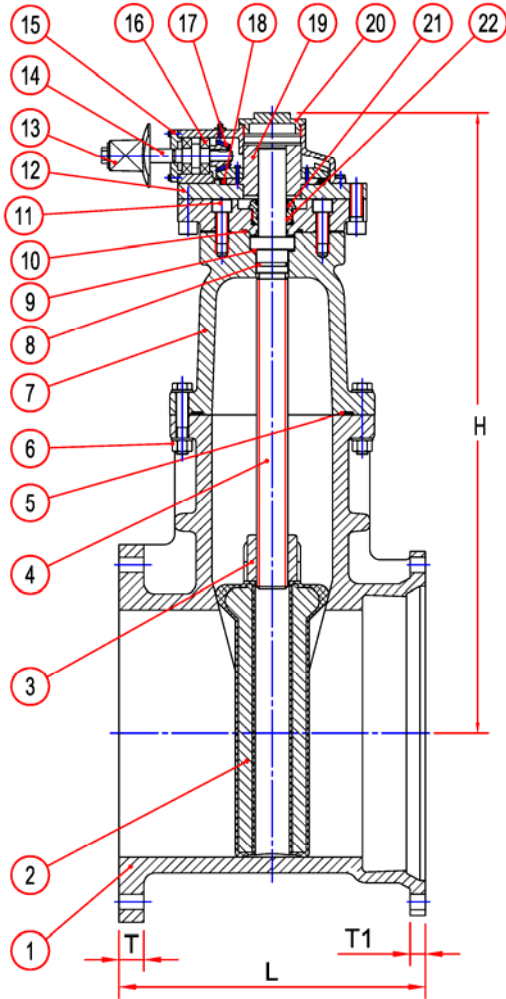

Spur gear configuration, available.
Gears can be rotated in 90° increments.

Features:

- Design and Materials Exceed AWWA C509, C515 & C550.
- Flanges Conform to ANSI B16.1, Class 150, MJ
Conforms to ANSI/AWWA .
- Ductile Iron: Body, Bonnet, Wedge, Gland.
- Fusion Bonded Epoxy Coatings 12 Mils In and Out
per AWWA C550.*
- Stainless Steel Nuts, Bolts, and Washers.
- Bronze or Stainless Steel Stem.
- Ductile Iron, EPDM Encapsulated Wedge.
- EPDM Gaskets and O-Rings.
- 250 PSI Working Pressure.
- Working Temperature: EPDM 33°F to 248°F.
- Available with Bypass.
- 2" AWWA Ductile Iron Operating Nut.

No.	Part Name	Materials
1	Body	Ductile Iron ASTM A536 65-45-12
2	Wedge	Ductile Iron EPDM Encapsulated
3	Stem Nut	Aluminum Bronze
4	Stem	Bronze or Stainless Steel
5	O-Ring Gasket	EPDM
6	Bolt	Stainless Steel AISI 304
7	Bonnet	Ductile Iron ASTM A536 65-45-12
8	O-Ring	EPDM
9	Thrust Bearing	Copper ASTM B16
10	O-Ring	EPDM
11	Bolt	Stainless Steel AISI 304
12	Bottom Cap	Cast Iron ASTM A126 Class B
13	2" Operating Nut	Ductile Iron ASTM A536 65-45-12
14	Shaft	Carbon Steel AISI 1045
15	Pressure Cover	Cast Iron ASTM A126 Class B
16	Housing	Cast Iron ASTM A126 Class B
17	Bevel Gear	Carbon Steel AISI 1045
18	Ball	Carbon Steel AISI 1045
19	Driving Sleeve	Ductile Iron ASTM A536 65-45-12
20	Top Cover	Cast Iron ASTM A126 Class B
21	Sealing Sleeve	Brass ASTM B15 C083600
22	O-Ring	EPDM

Dimensions:

Size	Model	L	H	T	T1	Approx. Weight
18"	6618	19"	44"	1½"	1"	1,210#
20"	6620	19⅝"	52"	1¾"	1"	1,670#
24"	6624	21⅝"	58"	1⅞"	1"	2,530#