

# Resilient Seated Solid Wedge Gate Valve - Series 6600

AWWA C509 & C515 ▪ NRS Type ▪ FL x MJ ▪ Sizes 2" - 16"

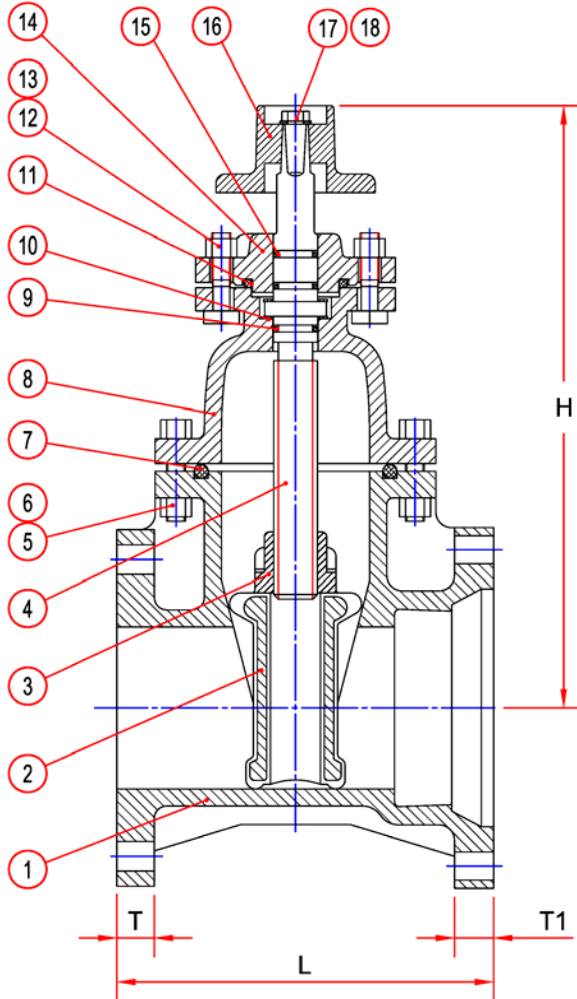

No.	Part Name	Materials
1	Body	Ductile Iron ASTM A536 65-45-12
2	Wedge	Ductile Iron EPDM Encapsulated
3	Stem Nut	Aluminum Bronze
4	Stem	Bronze or Stainless Steel
5	Nut	Stainless Steel AISI 304
6	Bolt	Stainless Steel AISI 304
7	O-Ring Gasket	EPDM
8	Bonnet	Ductile Iron ASTM A536 65-45-12
9	O-Ring	EPDM
10	Thrust Bearing	Copper ASTM B16
11	O-Ring	EPDM
12	Bolt	Stainless Steel AISI 304
13	Nut	Stainless Steel AISI 304
14	Gland	Ductile Iron ASTM A536 65-45-12
15	O-Ring	EPDM
16	2" Operating Nut	Ductile Iron ASTM A536 65-45-12
17	Bolt	Stainless Steel AISI 304
18	Washer	Stainless Steel AISI 304

## Features:

- Design and Materials Exceed AWWA C509, C515 & C550.
- Flanges Conform to ANSI B16.1, Class 150, MJ Conforms to ANSI/AWWA .
- Ductile Iron: Body, Bonnet, Wedge, and Gland.
- Fusion Bonded Epoxy Coatings 12 Mils In and Out per AWWA C550.\*
- Stainless Steel Nuts, Bolts, and Washers.
- Bronze or Stainless Steel Stem.
- Ductile Iron, EPDM Encapsulated Wedge.
- EPDM Gaskets and O-Rings.
- 250 PSI Working Pressure.
- Working Temperature: EPDM 33°F to 248°F.
- 2" AWWA Ductile Iron Nut Operator.

## Dimensions:

Size	Model	L	H	T	T1	Approx. Weight
2"	6602	8½"	9¾"	⅝"	1"	44#
2½"	6625	8"	11"	¾"	1"	46#
3"	6603	8¾"	13½"	¾"	1"	48#
4"	6604	9½"	15½"	1"	1"	60#
5"	6605	10½"	16½"	1"	1"	99#
6"	6606	11⅞"	18¼"	1"	1"	101#
8"	6608	12"	22½"	1⅞"	1"	160#
10"	6610	13⅞"	25½"	1¼"	1"	240#
12"	6612	14½"	30½"	1¼"	1¼"	370#
14"	6614	17½"	34"	1⅝"	1¼"	672#
16"	6616	18"	40¼"	1½"	1¼"	830#