

Resilient Seated Solid Wedge Gate Valve - Series 6900

AWWA C509 & C515 ▪ NRS Type ▪ MJ x MJ ▪ Sizes 2" - 16"

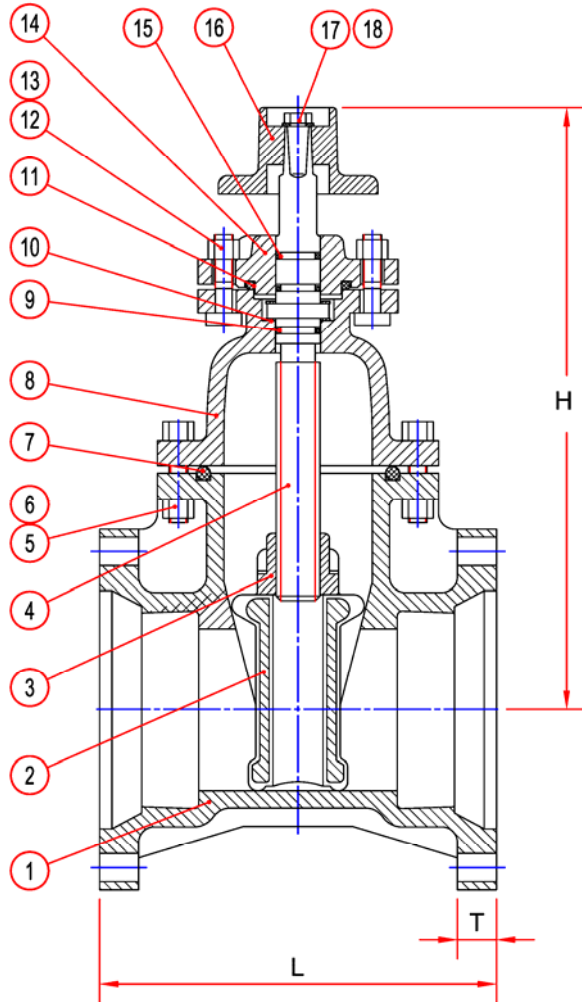

No.	Part Name	Materials
1	Body	Ductile Iron ASTM A536 65-45-12
2	Wedge	Ductile Iron EPDM Encapsulated
3	Stem Nut	Aluminum Bronze
4	Stem	Bronze or Stainless Steel
5	Nut	Stainless Steel AISI 304
6	Bolt	Stainless Steel AISI 304
7	O-Ring Gasket	EPDM
8	Bonnet	Ductile Iron ASTM A536 65-45-12
9	O-Ring	EPDM
10	Thrust Bearing	Copper ASTM B16
11	O-Ring	EPDM
12	Bolt	Stainless Steel AISI 304
13	Nut	Stainless Steel AISI 304
14	Gland	Ductile Iron ASTM A536 65-45-12
15	O-Ring	EPDM
16	2" Operating Nut	Ductile Iron ASTM A536 65-45-12
17	Bolt	Stainless Steel AISI 304
18	Washer	Stainless Steel AISI 304

Features:

- Design and Materials Exceed AWWA C509, C515 & C550.
- MJ Ends Conform to ANSI/AWWA.
- Ductile Iron: Body, Bonnet, Wedge, and Gland.
- Fusion Bonded Epoxy Coatings 12 Mils In and Out per AWWA C550.*
- Stainless Steel Nuts, Bolts and Washers.
- Bronze or Stainless Steel Stem.
- Ductile Iron, EPDM Encapsulated Wedge.
- EPDM Gaskets and O-Rings.
- 250 PSI Working Pressure.
- Working Temperature: EPDM 33°F to 248°F.
- 2" AWWA Ductile Iron Nut Operator.

Dimensions:

Size	Model	L	H	T	Approx. Weight
2"	6902	8"	9 ⁷ / ₈ "	1"	45#
2 ¹ / ₂ "	6925	8 ¹ / ₂ "	11"	1"	52#
3"	6903	9"	13 ¹ / ₂ "	1"	67#
4"	6904	10"	15 ¹ / ₂ "	1"	94#
5"	6905	11"	16 ¹ / ₂ "	1"	131#
6"	6906	11 ¹ / ₂ "	18 ¹ / ₄ "	1"	140#
8"	6908	12 ¹ / ₂ "	22 ¹ / ₂ "	1"	210#
10"	6910	14 ³ / ₄ "	25 ¹ / ₂ "	1"	356#
12"	6912	14 ⁷ / ₈ "	30 ¹ / ₂ "	1 ¹ / ₄ "	540#
14"	6914	17"	34 ¹ / ₂ "	1 ¹ / ₄ "	716#
16"	6916	17"	40 ¹ / ₄ "	1 ¹ / ₄ "	1,168#