

Resilient Seated Solid Wedge Gate Valve With Bevel Gear Operator - Series 6900

AWWA C509 & C515 ▪ NRS Type ▪ MJ x MJ ▪ Sizes 30" - 48"

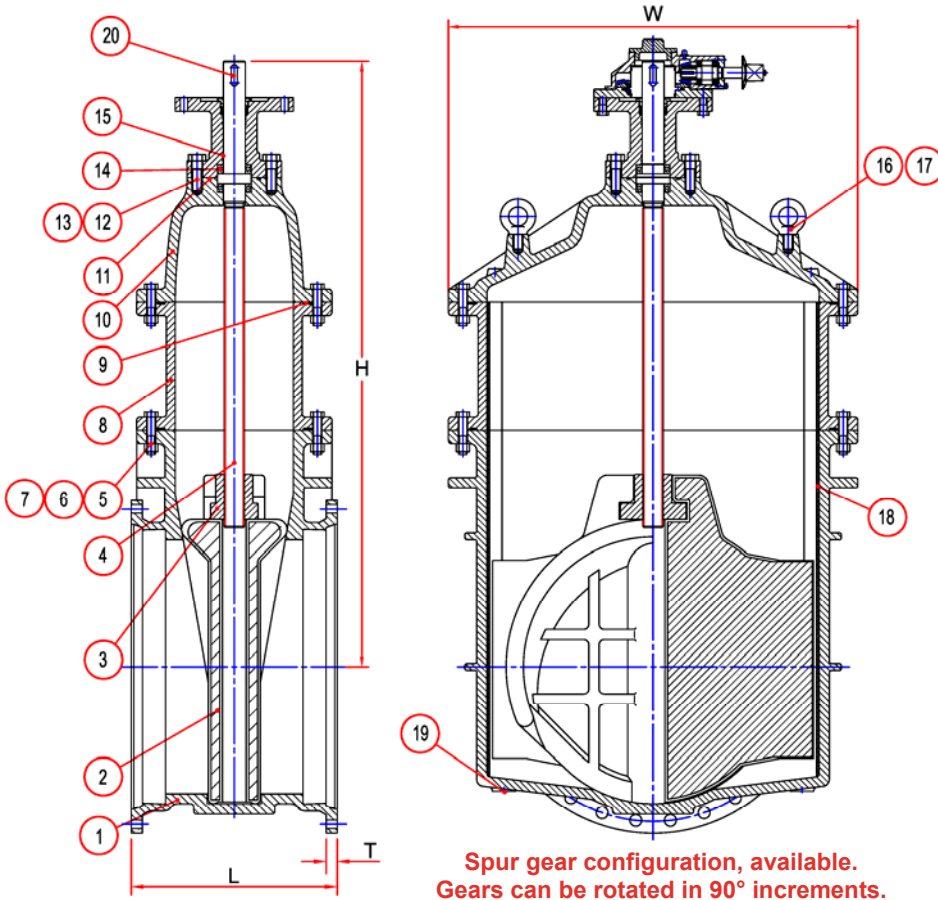

| No. | Part Name | Materials |
|-----|----------------|------------------------------------|
| 1 | Body | Ductile Iron ASTM A536 65-45-12 |
| 2 | Wedge | Ductile Iron EPDM Encapsulated |
| 3 | Stem Nut | Aluminum Bronze |
| 4 | Stem | Bronze or Stainless Steel |
| 5 | Bolt | Stainless Steel AISI 304 |
| 6 | Nut | Stainless Steel AISI 304 |
| 7 | Washer | Stainless Steel AISI 304 |
| 8 | Bonnet Adapter | Ductile Iron ASTM A536 65-45-12 |
| 9 | O-Ring Gasket | EPDM |
| 10 | Bonnet | Ductile Iron ASTM A536 65-45-12 |
| 11 | O-Ring | EPDM |
| 12 | Bolt | Stainless Steel AISI 304 |
| 13 | Nut | Stainless Steel AISI 304 |
| 14 | Thrust Bearing | Stainless Steel AISI 304 |
| 15 | O-Ring | EPDM |
| 16 | Eye Bolt | Carbon Steel. Zinc Plated |
| 17 | Washer | Stainless Steel ANSI 316 |
| 18 | Track | Stainless AISI 316 |
| 19 | Plug | Brass ASTM B16 |
| 20 | Key | Carbon Steel AISI 1045 |

Features:

- Design and Materials Exceed AWWA C509, C515 & C550.
- MJ Ends Conform to ANSI/AWWA.
- Ductile Iron: Body, Bonnet, Wedge, and Gland.
- Fusion Bonded Epoxy Coatings 12 Mils In and Out per AWWA C550.*
- Stainless Steel Nuts, Bolts and Washers.
- Bronze or Stainless Steel Stem.
- Ductile Iron, EPDM Encapsulated Wedge.
- EPDM Gaskets and O-Rings.
- 250 PSI Working Pressure.
- Working Temperature: EPDM 33°F to 248°F.
- Available with Bypass.
- 2" AWWA Ductile Iron Nut Operator.

Dimensions:

| Size | Model | L | H | W | T | Approx. Weight |
|------|-------|-----|------|------|-----|----------------|
| 30" | 6930 | 24" | 70" | 47¾" | 2⅞" | 5,294# |
| 36" | 6936 | 28" | 81" | 54¾" | 2⅞" | 8,494# |
| 42" | 6642 | 36" | 86½" | 66¾" | 2⅝" | 13,127# |
| 48" | 6948 | 43" | 96" | 75½" | 2¾" | 18,434# |