

1 Piece Reduced Port Ball Valves: 1/2" - 2"

Fire Safe, API 607 4th Edition Certified



Flow-Tek's Model S20 ball valves offer a compact, one piece body design. The one piece body supplies maximum structural strength while minimizing the number of potential leak paths.

These valves feature quarter turn operation, bottom entry blowout proof stems and low operating torque. Live-loaded, self-adjusting stem seals automatically adjust to compensate for changes in wear and temperature.

Fire Safe - Certified to API 607 4th Edition
Model S20 valves have been thoroughly fire tested and meet these latest standards. Additionally, the adjustable Graphite stem packing provides reduced torque and a very high cycle life.

Other features include replaceable seats and seals, stainless steel safety latch handles and high quality investment cast bodies. All bodies are marked with a foundry heat number for full traceability.

Pressure Rating 2000 psi WOG

Steam Rating 150 psi WSP

End Connections Threaded

Body Material Stainless Steel

Actuator Mounting All bodies offer an integrally cast actuator mounting pad to ensure ease of automation.

COMPONENTS AND MATERIALS

Item	Description	Stainless Steel	Qty.
1	Body	ASTM A351 Gr CF8M	1
2	Body Insert	ASTM A351 Gr CF8M	1
3	Ball	ASTM A351 Gr CF8M	1
4A	Seat*	Carbon Filled PTFE	1
4B	Seat Support	ASTM A351 Gr CF8M	1
5	Stem	ASTM A479 Type 316	1
6	Body Seal*	Graphite* / RPTFE	1
10	Anti-Static Device	SS304	2
12	Thrust Washer*	RPTFE	1
14	Stem Packing*	Graphite* / RPTFE	1
15	Gland Ring	SS304	1
18	Belleville Washer	SS301	2
19	Lock Washer	SS304	1
25	Handle	SS304	1
26	Handle Lock Nut	SS304	2
28	Handle Sleeve	Vinyl	1
29	Locking Device	SS304	1

* These parts are included in repair kit.

*Fire Safe valves / Non Fire Safe valves.

DIMENSIONS

Size ins mm	A	øB	C	C1	C2	D	G	H	U UNC	C _V	Weight lbs kg
1/2 15	2.64 67	0.36 9.2	1.73 44	0.53 13.5	1.1 28	4.37 111	0.50 12.7	1.12 28.5	10-24	5.5	0.3 .14
3/4 20	2.80 71	0.49 12.5	1.89 48	0.65 16.5	1.34 34	4.37 111	0.50 12.7	1.12 28.5	10-24	10.0	0.4 .18
1 25	3.35 85	0.63 16	2.36 60	0.81 20.5	1.59 40.5	5.55 141	0.87 22.1	1.37 34.8	10-24	16.3	0.7 .32
1 1/4 32	3.70 94	0.79 20	2.56 65	0.98 25	1.77 45	5.55 141	0.87 22.1	1.37 34.8	10-24	20.0	1.02 .46
1 1/2 40	3.94 100	0.98 25	2.80 71	1.12 28.5	2.11 53.5	6.34 161	0.93 23.6	1.50 38.1	1 1/4 - 20	37.0	1.3 .59
2 50	4.65 118	1.26 32	3.03 77	1.36 34.5	2.32 59	6.34 161	0.93 23.6	1.50 38.1	1 1/4 - 20	60.0	2.05 .93

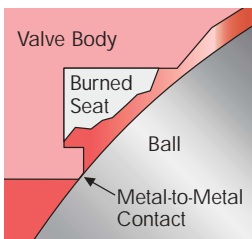
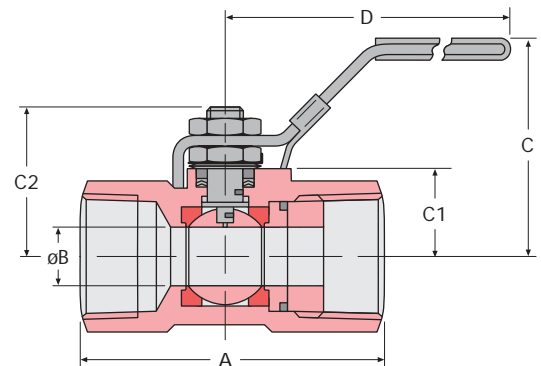
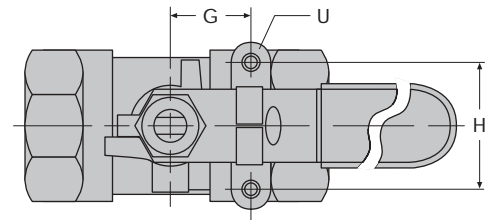
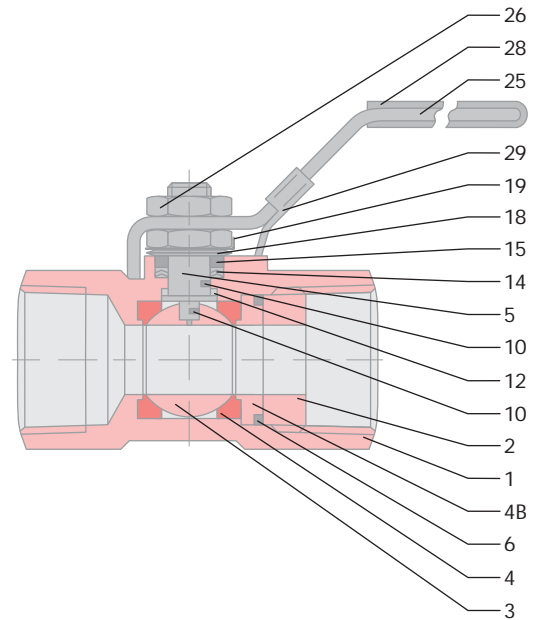

Fire Safe Flow-Tek's Model S20 valves are certified fire safe. In the event of a fire, after heat destroys the primary resilient seat, the ball makes contact with the secondary metal seat, forming a secure seal. The graphite body seal prevents external leakage. The graphite live-loaded stem packing prevents stem leakage. All valves have anti-static devices as standard, grounding ball and stem to body.

PRESSURE / TEMPERATURE

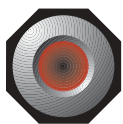
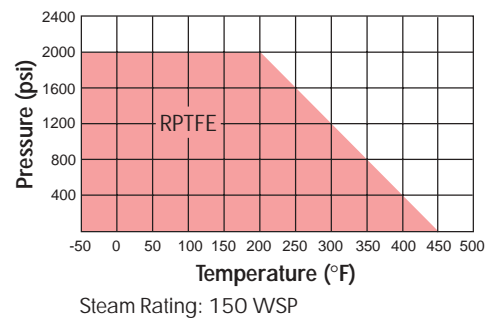

Flow-Tek

A Subsidiary of BRAY INTERNATIONAL, Inc.
 11850 Tanner Road Houston, Texas 77041
 832.912.2300 Fax: 832.912.2301
 www.flow-tek.com

All statements, technical information, and recommendations in this bulletin are for general use only. Consult Flow-Tek representatives or factory for the specific requirements and material selection for your intended application. The right to change or modify product design or product without prior notice is reserved.