

# (Patented) Model 206-PGM / 206-PGM\*

\*Single Rolling Diaphragm

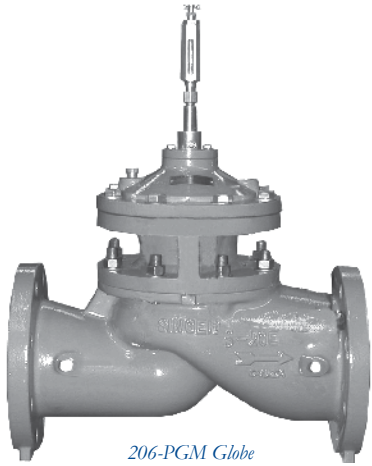

## Reduced Port, Integral Back-Up, Dual Diaphragm Automatic Control Valve



206-PGM Globe

For particularly sensitive applications and/or valves that are difficult to access and maintain, the Singer Model PGM provides integral back-up control and the ability to signal should the desired function move off limits. The Singer Model PGM also includes the ability to provide an independent and very positive shut down override.

SINGER MODEL 206-PGM is a version of the standard, single chamber PG valve. The modifications provide the following features and benefits:

- Back-up diaphragm / inner valve system.
- Back-up components are kept out of the main stream until called into operation.
- Totally self contained.
- Modulating or emergency close back-up.
- Extremely positive shut-off.
- Back-up pilot system (optional - see PR-SM bulletin)
- Annunciation if controlled function goes "OFF LIMITS" with SPDT Limit Switch (optional).
- Emergency close for security breach or earthquake.

- WHEN YOU NEED THAT EXTRA SECURITY!
- GLOBE OR ANGLE
- UNINTERRUPTED CONTROL, EVEN WITH A DIAPHRAGM OR PILOT SYSTEM FAILURE
- REMOTE ANNUNCIATION WHEN SECONDARY OPERATING SYSTEM IS TRIGGERED AVAILABLE AS OPTION
- SIMPLE CONSTRUCTION - FULL IN LINE SERVICE WITH CONVENTIONAL COMPONENTS
- REDUCES UNNECESSARY MAINTENANCE

### When Ordering Please Specify

1. Catalog Model #
2. Globe or Angle Pattern
3. End Connections
4. Valve Size

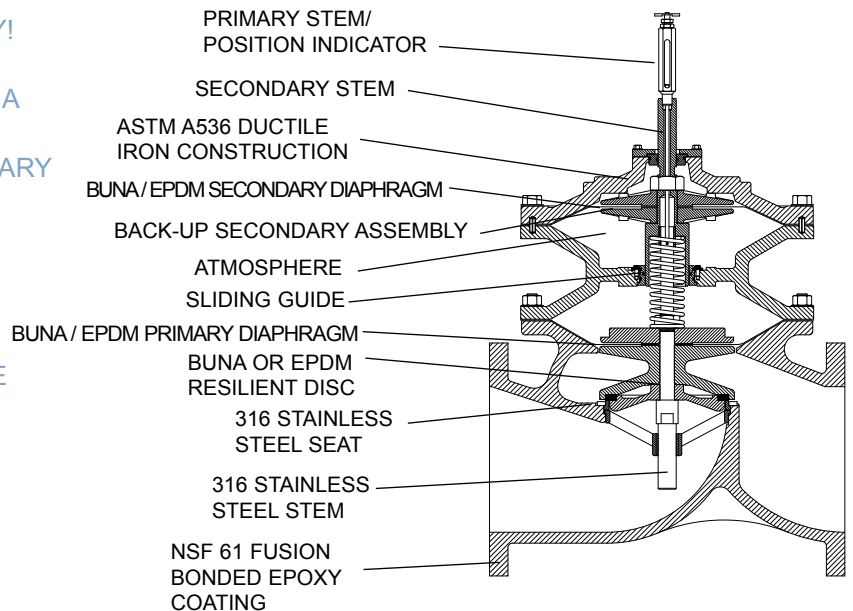

### Valve Sizes & Materials:

Valve Materials		
	Standard	Optional
Ductile		
Available Sizes	Flanged	
Globe	4" to 36" (100-900mm)	
Angle	4" to 8" (100mm-200mm)	
Valve Components		
1. Valve Body, Cover	ASTM A 536 - 65/45/12 Ductile Iron	
2. Seat Ring	AISI 316 Stainless Steel	
3. Disc Retainer	B62 Bronze / A48 or A536 Ductile Iron	AISI 316 Stainless Steel
4. Stem	AISI 316 Stainless Steel	
5. Stem Nut	B16 Brass	AISI 316 Stainless Steel
6. Spring	316 Stainless Steel	316 Stainless Steel
7. Guide Bushings	B16 Brass or SAE 660 Bronze	AISI 316 Stainless Steel
8. Diaphragm	EPDM / Buna-N	EPDM / Buna-N / Viton (limited sizes)
9. Resilient Disc	EPDM	Buna-N / Viton (limited sizes)
10. Coating	NSF61 Approved Fusion Bonded Epoxy	
11. Fasteners	AISI 18-8 Stainless Steel	AISI 316 Stainless Steel



206-PGM Angle

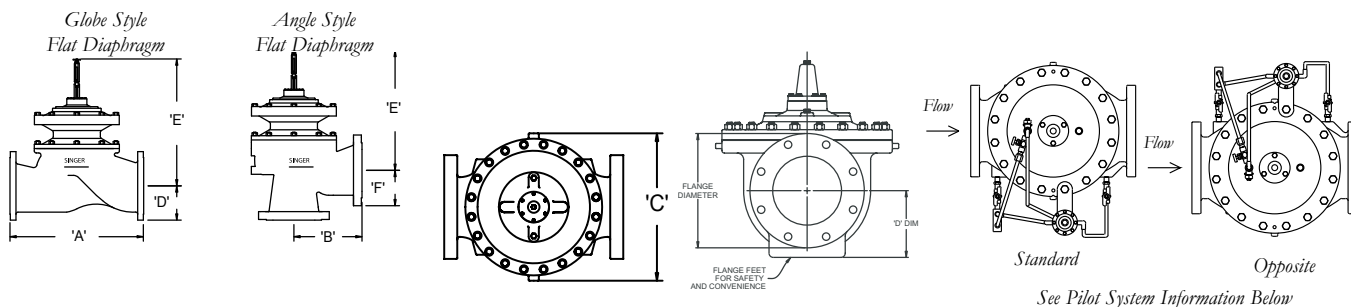

ANSI Valve Data (US Units) / see following page for additional data:

Size	DWG	Standard	Flat Diaphragm System			
Inches	REF	ANSI	4"	6"	8"	10"
<b>All figures shown in inches unless otherwise stated</b>						
<b>Globe Dimensions</b>						
Lay Length	A	FNPT	-	-	-	-
Centerline to Bottom	D	FNPT	-	-	-	-
Lay Length	A	150F	15.00	20.13	25.00	24.50
Centerline to Bottom	D	150F	4.60	5.60	6.75	8.00
Lay Length	A	300F	15.63	21.00	26.00	25.88
Centerline to Bottom	D	300F	5.00	6.25	7.50	8.63
<b>Angle Dimensions</b>						
Center Inlet to Discharge	B	FNPT	-	-	-	-
Center Discharge to Inlet	F	FNPT	-	-	-	-
Center Inlet to Discharge	B	150F	7.56	10.19	12.50	-
Center Discharge to Inlet	F	150F	5.94	6.19	9.00	-
Center Inlet to Discharge	B	300F	7.88	10.63	13.00	-
Center Discharge to Inlet	F	300F	6.25	6.81	9.50	-
<b>Common Dimensions (Globe and Angle)</b>						
Width	C		10.00	12.50	16.00	20.00
Height (To Indicator) Globe	E		19.13	20.88	23.38	30.63
Height (To Indicator) Angle	E		17.38	19.25	20.50	-
Body Port Tapping		FNPT	3/8	3/8	3/8	1/2
Stem Cap Plug		MNPT	3/8	3/8	3/8	3/8
Cover Port Tapping		FNPT	3/8	3/8	1/2	1/2
Valve Stroke			1 1/8	1 7/16	1 11/16	2 7/8
Displaced Bonnet Volume (Gallons)			0.09	0.20	0.56	1.67
Approx. Shipping Weight (Lbs.)			150	210	385	585
<b>Capacities (USPGM) Globe &amp; Angle</b>						
CV - Globe			150	250	505	985
CV - Angle			150	250	550	-
Continuous (Globe)			580	1025	2300	4100
Intermittent (Globe)			690	1190	2700	4670
Momentary (Globe)			1236	2160	4800	8400
<b>Maximum Pressure Ratings (Ductile Only)</b>						
PSI		FNPT	-	-	-	-
PSI		150F	250	250	250	250
PSI*		300F	400	400	400	400
* Valves rated and stamped 400 PSI as standard. Valves rated and stamped 600 PSI on request.						
<b>Maximum Temperature</b>						
Fahrenheit			180°	180°	180°	180°

**NOTES**

- Drilled as per ANSI B16.42.
- Class 150 machined flat faced / Class 300 machined raised faced.
- Castings are based on ANSI Class 150 or Class 300 standards.
- Consult the factory if working pressure exceeds 300 psi.

Add a minimum 6" (150mm) on one side, for **Pilot System**. Pilot system is installed as "standard" ("opposite" please specify). Dimensions are nominal. Allow 1/8" (3mm) for machining tolerance. Allow one to three feet for installation and maintenance clearances. Consult factory for certified dimensions. Install with stem vertical is preferred, 10" (250mm) and larger is mandatory.

# Model 206-PGM / 206-PGM\*

\*Single Rolling Diaphragm

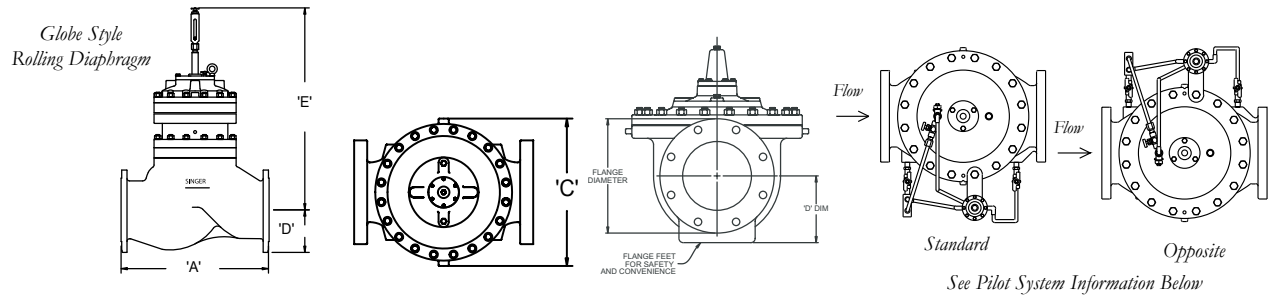

See Pilot System Information Below

ANSI Valve Data (US Units) / see previous page for additional data:

Size	DWG	Standard	Rolling Diaphragm System							
Inches	REF	ANSI	12"	16"	18"	20"	24" x 16"	24" x 20"	30"	36"
All figures shown in inches unless otherwise stated.										
<b>Globe Dimensions</b>										
Lay Length	A	FNPT	-	-	-	-	-	-	-	-
Centerline to Bottom	D	FNPT	-	-	-	-	-	-	-	-
Lay Length	A	150F	27.50	36.00	42.00	45.00	50.50	61.50	69.93	69.93
Centerline to Bottom	D	150F	9.50	11.75	12.50	13.93	16.50	17.13	20.68	23.75
Lay Length	A	300F	29.00	37.63	43.63	46.63	52.25	63.25	-	-
Centerline to Bottom	D	300F	10.25	12.75	14.00	15.25	18.00	19.65	-	-
<b>Angle Dimensions</b>										
Center Inlet to Discharge	B	FNPT	-	-	-	-	-	-	-	-
Center Discharge to Inlet	F	FNPT	-	-	-	-	-	-	-	-
Center Inlet to Discharge	B	150F	-	-	-	-	-	-	-	-
Center Discharge to Inlet	F	150F	-	-	-	-	-	-	-	-
Center Inlet to Discharge	B	300F	-	-	-	-	-	-	-	-
Center Discharge to Inlet	F	300F	-	-	-	-	-	-	-	-
<b>Common Dimensions (Globe and Angle)</b>										
Width	C		22.13	26.00	31.50	31.50	36.00	36.00	49.75	49.75
Height (To Indicator) Globe	E		39.38	44.56	53.00	53.00	53.00	58.00	61.50	61.50
Height (To Indicator) Angle	E		-	-	-	-	-	-	-	-
Body Port Tapping		FNPT	3/4	3/4	3/4	3/4	3/4	3/4	3/4	3/4
Stem Cap Plug		MNPT	3/4	3/4	3/4	3/4	3/4	3/4	3/4	3/4
Cover Port Tapping		FNPT	3/4	3/4	3/4	3/4	3/4	3/4	3/4	3/4
Valve Stroke			3 1/4	3 1/4	4 3/4	4 3/4	4 3/4	5 9/16	6	6
Displaced Bonnet Volume (Gallons)			1.50	2.30	6.75	6.75	6.75	11.73	14.75	14.75
Approx. Shipping Weight (Lbs.)			880	1540	2530	2730	2980	5400	7300	7500
<b>Capacities (USPGM) Globe &amp; Angle</b>										
CV - Globe			1550	2200	3300	3400	3500	6150	7800	8000
CV - Angle			-	-	-	-	-	-	-	-
Continuous (Globe)			6400	9230	16500	16500	16500	17400	33650	33800
Intermittent (Globe)			7370	10470	20915	20915	20915	21700	37490	37640
Momentary (Globe)			13200	19200	30000	30050	30100	39000	67490	67640
<b>Maximum Pressure Ratings (Ductile Only)</b>										
PSI		FNPT	-	-	-	-	-	-	-	-
PSI		150F	250	250	250	250	250	250	250	250
PSI*		300F	400	400	400	400	400	400	400	400
* Valves rated and stamped 400 psi as standard. Valves rated and stamped 600 psi on request.										
<b>Maximum Temperature</b>										
Fahrenheit			180°	180°	180°	180°	180°	180°	180°	180°

**NOTES**

- Drilled as per ANSI B16.42.
- Class 150 machined flat faced / Class 300 machined raised faced.
- Castings are based on ANSI Class 150 or Class 300 standards.
- Consult the factory if working pressure exceeds 300 psi.

Add a minimum 6" (150mm) on one side, for Pilot System. Pilot system is installed as "standard" ("opposite" please specify). Dimensions are nominal. Allow 1/8" (3mm) for machining tolerance. Allow one to three feet for installation and maintenance clearances. Consult factory for certified dimensions. Install with stem vertical is preferred, 10" (250mm) and larger is mandatory.

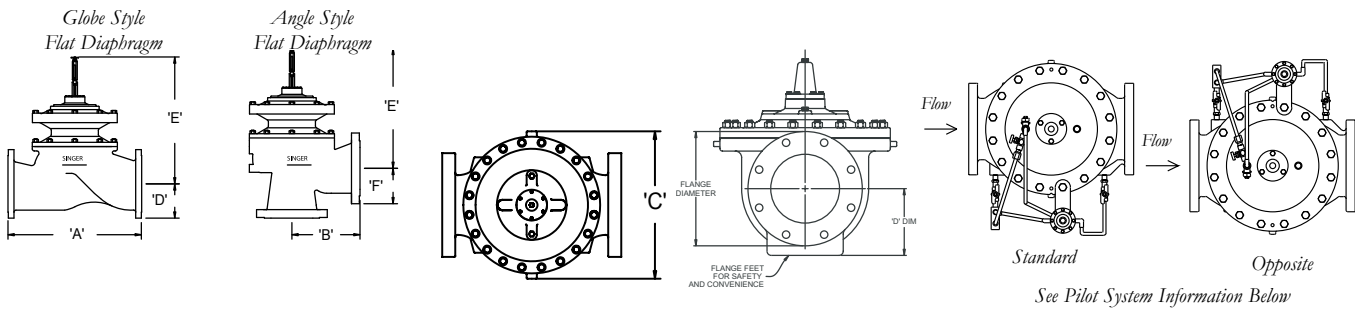

ANSI Valve Data (Metric Units) / see following page for additional data:

Size	DWG	Standard	Flat Diaphragm System			
MM	REF	ANSI	100	150	200	250
All figures shown in mm unless otherwise stated						
<b>Globe Dimensions</b>						
Lay Length	A	FNPT	-	-	-	-
Centerline to Bottom	D	FNPT	-	-	-	-
Lay Length	A	150F	381	511	635	622
Centerline to Bottom	D	150F	117	142	171	203
Lay Length	A	300F	397	533	660	657
Centerline to Bottom	D	300F	127	159	191	219
<b>Angle Dimensions</b>						
Center Inlet to Discharge	B	FNPT	-	-	-	-
Center Discharge to Inlet	F	FNPT	-	-	-	-
Center Inlet to Discharge	B	150F	192	259	318	-
Center Discharge to Inlet	F	150F	151	157	229	-
Center Inlet to Discharge	B	300F	200	270	330	-
Center Discharge to Inlet	F	300F	159	173	241	-
<b>Common Dimensions (Globe and Angle)</b>						
Width	C		254	318	406	508
Height (To Indicator) Globe	E		486	530	594	778
Height (To Indicator) Angle	E		441	489	521	-
Body Port Tapping	FNPT	Inches	3/8	3/8	3/8	1/2
Stem Cap Plug	MNPT	Inches	3/8	3/8	3/8	3/8
Cover Port Tapping	FNPT	Inches	3/8	3/8	1/2	1/2
Valve Stroke		mm	29	37	43	73
Displaced Bonnet Volume (Litres)			0.34	0.76	2.12	6.32
Approx. Shipping Weight (Kilograms)			68	95	175	265
<b>Capacities (L/s) Globe &amp; Angle</b>						
CV - Globe			3.6	6.0	12.1	23.6
CV - Angle			4.0	6.0	13.0	-
Continuous (Globe)			37	65	145	259
Intermittent (Globe)			44	75	170	295
Momentary (Globe)			78	136	303	530
<b>Maximum Pressure Ratings (Ductile Only)</b>						
Bar		FNPT	-	-	-	-
Bar		150F	17	17	17	17
Bar*		300F	27.6	27.6	27.6	27.6
* Valves rated and stamped 27.6 bar as standard. Valves rated and stamped 41 bar on request						
<b>Maximum Temperature</b>						
Celcius			82°	82°	82°	82°

**NOTES**

- Castings are based on ANSI Class 150 or Class 300 standards.
- ANSI Flanges drilled to ISO 2531/BS4504 PN10, 16, 25 or 40.
- Consult the factory if working pressure exceeds 20 Bar.

Add 6" (150mm) to each size for **Pilot System**. Pilot system installed as "standard" ("opposite" please specify). Dimensions are nominal. Allow 1/8" (6mm) for machining tolerances. Allow one to three feet (one meter) for installation and maintenance clearances. Consult factory for certified dimensions. Install with stem vertical is preferred, 12" (300mm) and larger is mandatory.

# Model 206-PGM / 206-PGM\*

\*Single Rolling Diaphragm

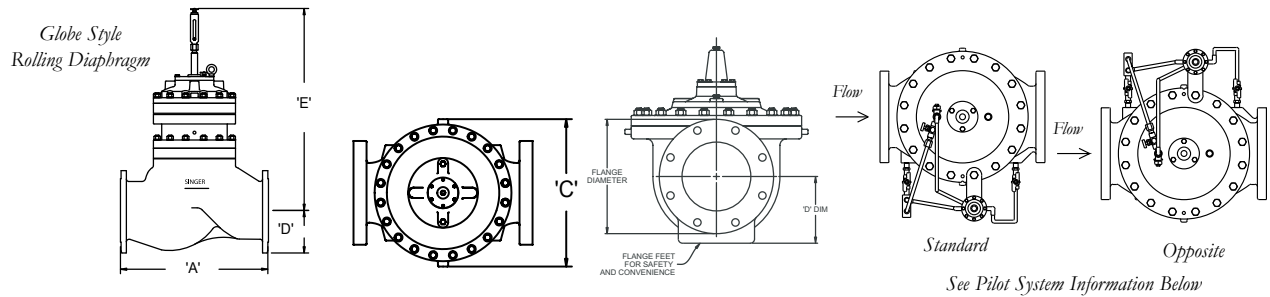

See Pilot System Information Below

ANSI Valve Data (Metric Units) / see previous page for additional data:

Size	DWG	Standard	Rolling Diaphragm System							
			300	400	450	500	600 x 400	600 x 500	700	900
MM	REF	ANSI	All figures shown in mm unless otherwise stated.							
<b>Globe Dimensions</b>										
Lay Length	A	FNPT	-	-	-	-	-	-	-	-
Centerline to Bottom	D	FNPT	-	-	-	-	-	-	-	-
Lay Length	A	150F	699	914	1067	1143	1283	1562	1607	1776
Centerline to Bottom	D	150F	241	298	318	354	419	435	499	603
Lay Length	A	300F	737	956	1108	1184	1327	1607	-	-
Centerline to Bottom	D	300F	260	324	356	387	457	499	-	-
<b>Angle Dimensions</b>										
Center Inlet to Discharge	B	FNPT	-	-	-	-	-	-	-	-
Center Discharge to Inlet	F	FNPT	-	-	-	-	-	-	-	-
Center Inlet to Discharge	B	150F	-	-	-	-	-	-	-	-
Center Discharge to Inlet	F	150F	-	-	-	-	-	-	-	-
Center Inlet to Discharge	B	300F	-	-	-	-	-	-	-	-
Center Discharge to Inlet	F	300F	-	-	-	-	-	-	-	-
<b>Common Dimensions (Globe and Angle)</b>										
Width	C		562	660	800	800	914	914	1264	1264
Height (To Indicator) Globe	E		1000	1132	1346	1346	1346	1473	1562	1562
Height (To Indicator) Angle	E		-	-	-	-	-	-	-	-
Body Port Tapping	FNPT	Inches	3/4	3/4	3/4	3/4	3/4	3/4	3/4	3/4
Stem Cap Plug	MNPT	Inches	3/4	3/4	3/4	3/4	3/4	3/4	3/4	3/4
Cover Port Tapping	FNPT	Inches	3/4	3/4	3/4	3/4	3/4	3/4	3/4	3/4
Valve Stroke		mm	83	83	120	120	120	143	150	150
Displaced Bonnet Volume (Litres)			5.67	8.69	25.55	25.55	25.55	44.41	55.83	55.83
Approx. Shipping Weight (Kilograms)			399	699	1148	1238	1352	2450	3311	3400
<b>Capacities (L/s) Globe &amp; Angle</b>										
CV - Globe			37	53	79	82	84	147.7	187	192
CV - Angle			-	-	-	-	-	-	-	-
Continuous (Globe)			404	582	1041	1041	1041	1098	2120	2132
Intermittent (Globe)			465	661	1320	1320	1320	1369	2362	2375
Momentary (Globe)			833	1211	1893	1896	1899	2461	4255	4267
<b>Maximum Pressure Ratings (Ductile Only)</b>										
Bar	FNPT		-	-	-	-	-	-	-	-
Bar	150F		17	17	17	17	17	17	17	17
Bar*	300F		27.6	27.6	27.6	27.6	27.6	27.5	27.6	27.6
* Valves rated and stamped 27.6 bar as standard. Valves rated and stamped 41 bar on request										
<b>Maximum Temperature</b>										
Celsius			82°	82°	82°	82°	82°	82°	82°	82°

**NOTES**

- Castings are based on ANSI Class 150 or Class 300 standards.
- ANSI Flanges drilled to ISO 2531/BS4504 PN10, 16, 25 or 40.
- Consult the factory if working pressure exceeds 20 Bar.

Add 6" (150mm) to each size for **Pilot System**. Pilot system installed as "standard" ("opposite" please specify). Dimensions are nominal. Allow 1/8" (6mm) for machining tolerances. Allow one to three feet (one meter) for installation and maintenance clearances. Consult factory for certified dimensions. Install with stem vertical is preferred, 12" (300mm) and larger is mandatory.

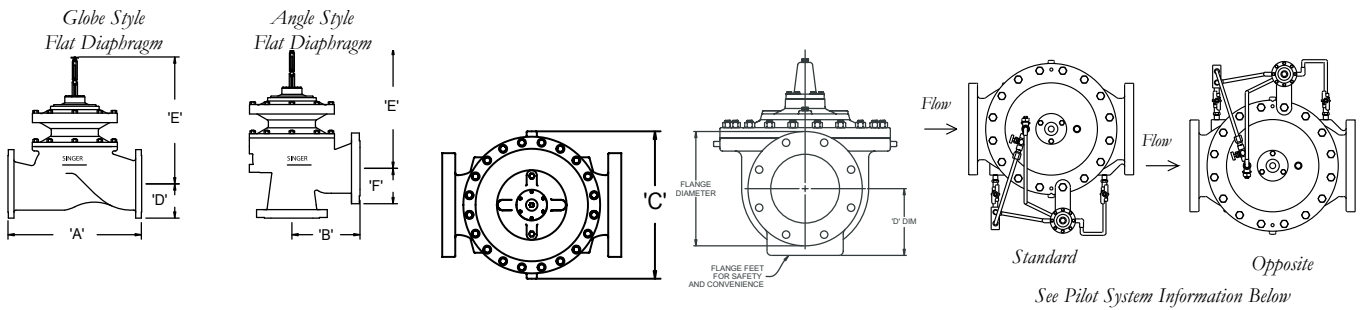

## ISO Valve Data (Metric Units) / see following page for additional data:

Size	DWG	Standard	Flat Diaphragm System			
MM	REF	ANSI	100	150	200	250
All figures shown in mm unless otherwise stated						
<b>Globe Dimensions</b>						
Lay Length	A	FNPT	-	-	-	-
Centerline to Bottom	D	FNPT	-	-	-	-
Lay Length	A	150F	381	511	635	622
Centerline to Bottom	D	150F	117	142	171	203
Lay Length	A	300F	397	533	660	657
Centerline to Bottom	D	300F	127	159	191	219
<b>Angle Dimensions</b>						
Center Inlet to Discharge	B	FNPT	-	-	-	-
Center Discharge to Inlet	F	FNPT	-	-	-	-
Center Inlet to Discharge	B	150F	192	259	318	-
Center Discharge to Inlet	F	150F	151	157	229	-
Center Inlet to Discharge	B	300F	200	270	330	-
Center Discharge to Inlet	F	300F	159	173	241	-
<b>Common Dimensions (Globe and Angle)</b>						
Width	C		254	318	406	508
Height (To Indicator) Globe	E		486	530	594	778
Height (To Indicator) Angle	E		441	489	521	-
Body Port Tapping	FNPT	Inches	3/8	3/8	3/8	1/2
Stem Cap Plug	MNPT	Inches	3/8	3/8	3/8	3/8
Cover Port Tapping	FNPT	Inches	3/8	3/8	1/2	1/2
Valve Stroke		mm	29	37	43	73
Displaced Bonnet Volume (Litres)			0.34	0.76	2.12	6.32
Approx. Shipping Weight (Kilograms)			68	95	175	265
<b>Capacities (L/s) Globe &amp; Angle</b>						
CV - Globe			3.6	6.0	12.1	23.6
CV - Angle			4.0	6.0	13.0	-
Continuous (Globe)			37	65	145	259
Intermittent (Globe)			44	75	170	295
Momentary (Globe)			78	136	303	530
<b>Maximum Pressure Ratings (Ductile Only)</b>						
Bar	FNPT		-	-	-	-
Bar	150F		17	17	17	17
Bar*	300F		27.6	27.6	27.6	27.6
* Valves rated and stamped 27.6 bar as standard. Valves rated and stamped 41 bar on request						
<b>Maximum Temperature</b>						
Celcius			82°	82°	82°	82°

### NOTES

- Castings are based on ANSI Class 150 or Class 300 standards.
- ANSI Flanges drilled to ISO 2531/BS4504 PN10, 16, 25 or 40.
- Consult the factory if working pressure exceeds 20 Bar.

Add 6" (150mm) to each size for **Pilot System**. Pilot system installed as "standard" ("opposite" please specify). Dimensions are nominal. Allow 1/8" (6mm) for machining tolerances. Allow one to three feet (one meter) for installation and maintenance clearances. Consult factory for certified dimensions. Install with stem vertical is preferred, 12" (300mm) and larger is mandatory.

# Model 206-PGM / 206-PGM\*

\*Single Rolling Diaphragm

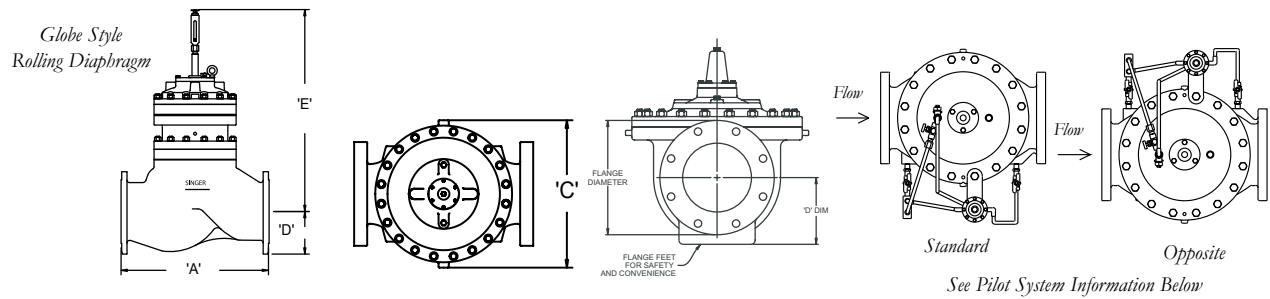

ISO Valve Data (Metric Units) / see previous page for additional data:

Size	DWG	Standard	Rolling Diaphragm System							
MM	REF	ANSI	300	400	450	500	600 x 400	600 x 500	700	900
All figures shown in mm unless otherwise stated.										
<b>Globe Dimensions</b>										
Lay Length	A	FNPT	-	-	-	-	-	-	-	-
Centerline to Bottom	D	FNPT	-	-	-	-	-	-	-	-
Lay Length	A	150F	699	914	1067	1143	1283	1562	1607	1776
Centerline to Bottom	D	150F	241	298	318	354	419	435	499	603
Lay Length	A	300F	737	956	1108	1184	1327	1607	-	-
Centerline to Bottom	D	300F	260	324	356	387	457	499	-	-
<b>Angle Dimensions</b>										
Center Inlet to Discharge	B	FNPT	-	-	-	-	-	-	-	-
Center Discharge to Inlet	F	FNPT	-	-	-	-	-	-	-	-
Center Inlet to Discharge	B	150F	-	-	-	-	-	-	-	-
Center Discharge to Inlet	F	150F	-	-	-	-	-	-	-	-
Center Inlet to Discharge	B	300F	-	-	-	-	-	-	-	-
Center Discharge to Inlet	F	300F	-	-	-	-	-	-	-	-
<b>Common Dimensions (Globe and Angle)</b>										
Width	C		562	660	800	800	914	914	1264	1264
Height (To Indicator) Globe	E		1000	1132	1346	1346	1346	1473	1562	1562
Height (To Indicator) Angle	E		-	-	-	-	-	-	-	-
Body Port Tapping	FNPT	Inches	3/4	3/4	3/4	3/4	3/4	3/4	3/4	3/4
Stem Cap Plug	MNPT	Inches	3/4	3/4	3/4	3/4	3/4	3/4	3/4	3/4
Cover Port Tapping	FNPT	Inches	3/4	3/4	3/4	3/4	3/4	3/4	3/4	3/4
Valve Stroke		mm	83	83	120	120	120	143	150	150
Displaced Bonnet Volume (Litres)			5.67	8.69	25.55	25.55	25.55	44.41	55.83	55.83
Approx. Shipping Weight (Kilograms)			399	699	1148	1238	1352	2450	3311	3400
<b>Capacities (L/s) Globe &amp; Angle</b>										
CV - Globe			37	53	79	82	84	147.7	187	192
CV - Angle			-	-	-	-	-	-	-	-
Continuous (Globe)			404	582	1041	1041	1041	1098	2120	2132
Intermittent (Globe)			465	661	1320	1320	1320	1369	2362	2375
Momentary (Globe)			833	1211	1893	1896	1899	2461	4255	4267
<b>Maximum Pressure Ratings (Ductile Only)</b>										
Bar	FNPT		-	-	-	-	-	-	-	-
Bar	150F		17	17	17	17	17	17	17	17
Bar*	300F		27.6	27.6	27.6	27.6	27.6	27.5	27.6	27.6
* Valves rated and stamped 27.6 bar as standard. Valves rated and stamped 41 bar on request										
<b>Maximum Temperature</b>										
Celsius			82°	82°	82°	82°	82°	82°	82°	82°

**NOTES**

- Castings are based on ANSI Class 150 or Class 300 standards.
- ANSI Flanges drilled to ISO 2531/BS4504 PN10, 16, 25 or 40.
- Consult the factory if working pressure exceeds 20 Bar.

Add 6" (150mm) to each size for **Pilot System**. Pilot system installed as "standard" ("opposite" please specify). Dimensions are nominal. Allow 1/8" (6mm) for machining tolerances. Allow one to three feet (one meter) for installation and maintenance clearances. Consult factory for certified dimensions. Install with stem vertical is preferred, 12" (300mm) and larger is mandatory.

## AVAILABLE OPTIONS

### VALVE POSITION INDICATORS:

- Model X129 limit switch assembly with S.P.D.T. limit switch
- Model X136/X156 analog position transmitters (4 to 20 mA)

All of which may be installed at the factory or as a field modification.

**MATERIALS OF CONSTRUCTION** for individual components can be upgraded from ductile iron, bronze and brass to stainless steel, for most sizes. Consult with the factory.

**DELTRIN STEM SLEEVE/OXY NITRIDE STEM** provides extra protection against mineral deposits. See Main Valve Options Section.

**INTERNAL DROP CHECK** option provides a built-in, drop check to mechanically prevent reverse flow. See Main Valve Options Section.

**GROOVED ENDS** - See Main Valve Options Section.

**RECLAIM WATER** - For Grey and Reclaim Water applications. See Main Valve Options Section.

**PILOTS & ACCESSORIES** - Singer Valve offers a wide range of Pilots & Accessories. See Pilots & Accessories Section.

## SELECTION

The Singer Model 206-PGM incorporates a second actuator. If the primary system and/or the main valve fails then the back-up pilot system takes over. Under normal operating conditions, there is no external discharge from the PGM. In modulating applications, when the back-up pilot system operates, there is a small (less than 1 USGPM (.06 L/s)) continuous discharge that should be taken to drain.

The primary pilot function can be duplicated in the secondary pilot system to provide continuing back-up operations or the secondary system can be used for override functions. Consult with the factory with your specific application requirements.

Sizing of PGM valves is based on the same criteria as standard PG models.

## SPECIFICATIONS

- Valve(s) shall be a hydraulically operated globe (angle) valve complete with an integral back-up actuator. The inner valve assembly shall be top and bottom guided by means of easily replaceable bearing bushings. In normal operation, the inner valve assembly shall be the only moving part and shall be securely mounted on a 316 stainless steel stem. The secondary system shall include a separate operating chamber and components, which will provide independent control on the primary valve. The stainless steel stem shall be provided with wrench flats on all valves 4" (100mm) to 16" (400mm), for ease of assembly and maintenance.
- All back-up components shall remain stationary, unstressed and will not interfere with normal valve operation until required.
- Back-up operation shall be initiated by either a remote emergency close signal or the controlled function being out of normal operating limits.
- All pressure containing components shall be constructed of ASTM A536-65/45/12 ductile iron. The flanges shall be designed to ANSI Class 150 or Class 300 standards. Flange drilling to ANSI shall be standard however British, ISO and other drillings shall be available upon request.
- Valve(s) shall have a protective fusion bonded epoxy coating internally and externally. The protective fusion bonded epoxy coating shall conform to the ANSI/AWWA C116/A21.16 (current version) specification.
- Valve(s) 10" (250mm) and smaller shall provide smooth "frictionless" motion with actuation being achieved by the use of a flat style BUNA / EPDM diaphragm. They shall be constructed of nylon fabric bonded with synthetic rubber. The diaphragms shall not be used as a seating surface. No lip seals or packing may be used to seal the actuator.
- Valve(s) 12" (300mm) and larger shall provide smooth "frictionless" motion and maximum low flow stability with actuation being achieved by the use of the Singer rolling diaphragm technology. The diaphragms shall not be used as a seating surface. No lip seals or packing may be used to seal the actuator.
- Bonnets shall be accurately located to bodies utilizing locating pins. Locating pins shall eliminate corrosion resulting from the use of uncoated ductile iron to ductile iron surfaces.
- The 316 stainless steel seat shall be bolted in place, utilizing "Spiralock" thread tapping technology. The 316 stainless steel seat ring shall be easily replaceable without special tools.
- The valve(s) shall form a drip tight seal between the stationary stainless steel seat ring and the resilient disc, which has a rectangular cross-section and is retained by clamping on three and one half sides. The resilient disc shall be constructed of Buna or EPDM for normal service conditions.
- All external fasteners shall be 18/8 stainless steel with 18/8 washers.
- All repairs and maintenance shall be possible without removing the valve from the line. To facilitate easy removal and replacement of the inner valve assembly and to reduce unnecessary wear on the guide, the stem shall be vertical when the valve is mounted in a horizontal line.
- Each valve shall be tested prior to shipment. The standard test shall include a pressure test and a full functional, operational test when pilots and accessories are fitted to suit a particular application.
- The valve(s) shall be covered by a minimum three year (3) warranty against defects in materials and workmanship. The stainless steel seat ring shall be covered by a lifetime replacement warranty.
- The valve shall be a Singer Model.... Refer to other Catalog Sections for further details.