

SIMPLE LEVER TYPE AIR RELEASE VALVE

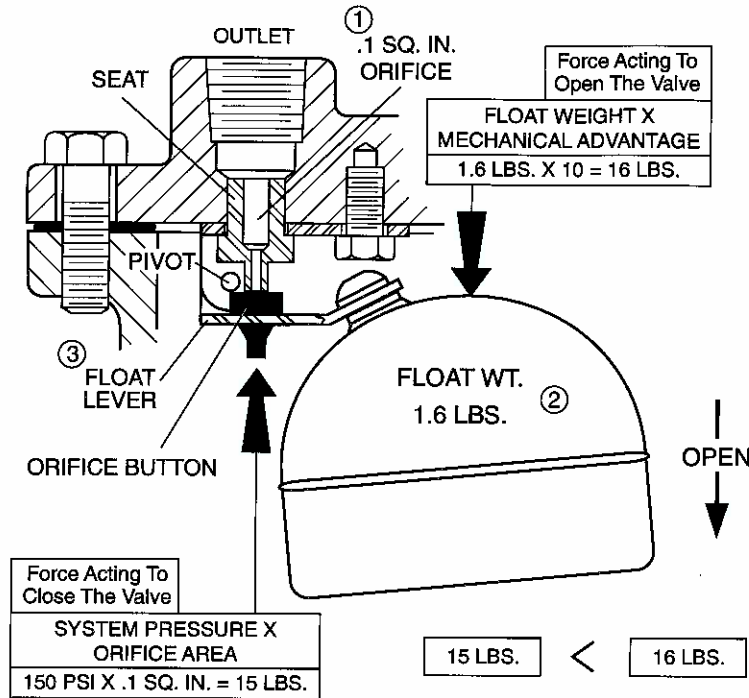

CONCLUSION: VALVE WILL OPEN AND VENT ACCUMULATED AIR.

This is intended to explain how an Air Release Valve functions when water in the valve has been displaced by accumulate air. It should be noted that when water is present in the valve it raises the buoyant float closing the valve orifice.

An Air Release Valve opens during system operation because forces acting to open the valve are greater than forces acting to hold the valve closed.

Forces acting to hold the valve closed.

In the absence of water, the only force acting to hold the valve closed is the systems working pressure. This is multiplied by the total area of the valves opening (the orifice^①) to atmosphere. The orifice of an Air Release valve is very small, Typically 1/16" - 3/16".

Example:	System pressure:	150 psi
	X total Orifice Area:	.1 sq. in.
		= 15 lbs. Acting to raise the float and close the valve orifice.

Forces acting to open the valve

The forces acting to open the valve are the weight of the valve float^② and the mechanical advantage provided by the float lever^③. The effect of atmospheric pressure on the valve is minimal due to the size of the orifice.

Example:	Valve float weight:	1.6 lbs.
	X mechanical advantage provided by lever:	10 lbs.
		= 16 lbs. Acting to lower the float and open the orifice.

Because the forces acting to open the valve (16 lbs.) is greater than the force to close the valve (15 lbs.), the valve will open during system operation. Again, these forces are negated when water is present in the valve raising the buoyant float and closing the valve orifice.

WHY AN AIR RELEASE VALVE OPENS DURING SYSTEM OPERATION

DATE 7-23-98

VAL-MATIC® VALVE AND MANUFACTURING CORP.

DRWG. NO. SS-1514

WHY AN AIR RELEASE VALVE OPENS DURING SYSTEM OPERATION COMPOUND LEVER TYPE

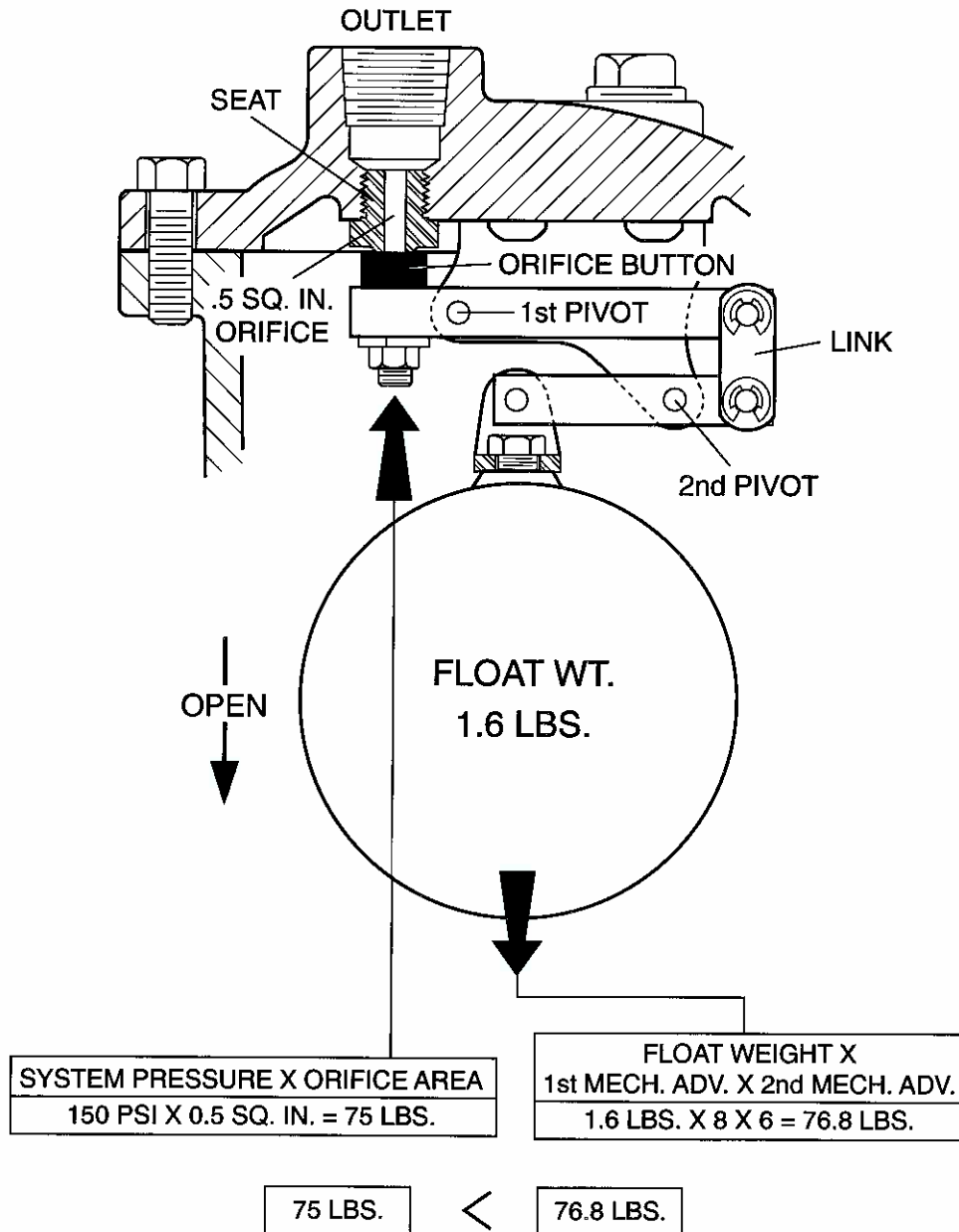

CONCLUSION: VALVE WILL OPEN AND VENT ACCUMULATED AIR.

WHY AN AIR RELEASE VALVE OPENS DURING SYSTEM OPERATION

DATE 7-23-98

VAL-MATIC® VALVE AND MANUFACTURING CORP.

DRWG. NO.

SS-1513