

## APPLICATION ENGINEERING GUIDE

### WELL SERVICE AIR VALVES FOR VERTICAL PUMPS

#### INTRODUCTION

The purpose of this guide is to provide background information on pumping applications and make recommendations for specifying and installing Well Service Air Valves for vertical pumps. A vertical pump, as shown below, lifts water from a water reservoir or well into a pipeline. When the pump is off, the suction water level is below the pump discharge pipe. The pump column refills with air after each pump stoppage.

Well Service Air Valves play an important roll in automatically venting air and controlling surges in pump columns. Well Service Air Valves are similar to Air/Vacuum Valves. They are designed to exhaust air on pump start-up and admit air upon pump shut down. They are typically provided with Anti-Slam Devices (page 2) and/or Dual Port Throttling Devices (page 3). The valve is a normally-open, float-operated valve which vents or admits air at high rates.

When water enters the valve, the float automatically rises and closes to prevent discharge of the water. The requirements for Air/Vacuum Valves are described in American Water Works Standard AWWA C512. Air/Vacuum Valves have a large orifice equal to the inlet size for discharging air in large volumes at low pressures, typically 2 psi.

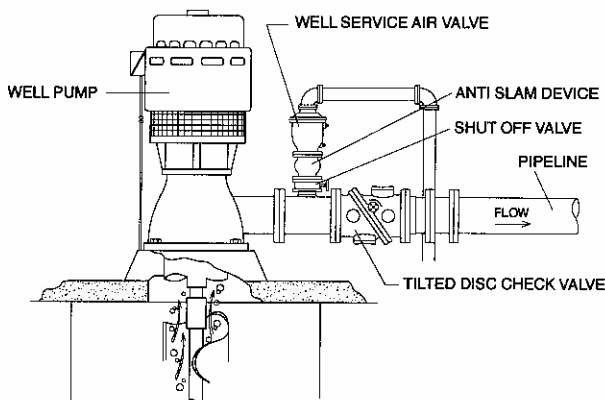

**Vertical Turbine Pump**

To properly select Well Service Air Valves for pump discharge, some fundamentals of surge control and entrapped air must first be understood.

#### SURGES

Surges (or water hammer) result from sudden changes in flow velocity. The effects of surges can be devastating because the magnitude of surges are approximately 50 psi for every 1 ft/sec change in flow velocity. And, the surge pressure is additive to the static pressure in the pipe.

For example, if a flow of 8 ft./sec is suddenly stopped in a pipe, a surge pressure as high as 400 psi above the static pressure may be produced. Hence, pumping systems are carefully designed with consideration to the starting and stopping sequences of the pumps.

#### ENTRAPPED AIR

For a pumping system to operate efficiently, any free air in the pipeline must be automatically removed. If air collects at the high points, a restriction occurs, which will cause headloss. The combination of air and water will also accelerate corrosion of the pipe wall. Air pockets can also move along the pipeline and pass through partially open valves causing sudden changes in the water velocity and surges. For example, if air is rapidly discharged from a hydrant, the high velocity water will be suddenly slowed because water is 200 times more dense than the air and cannot pass as quickly through the hydrant. Finally, air that reaches the end of the main will disturb the water systems of the end user. No one likes to open a faucet or flush a toilet and get a blast of air.

#### VERTICAL PUMPS

Vertical pumps have an air-filled discharge column when not running. For example, a well pump is typically submerged several hundred feet and isolated from the pipeline by a check valve mounted at ground level. When the pump is off, the water level drops to the normal water level in the well and a large column of air collects in the pump column.

Air is always present in the column of a vertical turbine pump installed over a wet well. If the vertical turbine pump is started without an air valve, the air in the pump column would be pressurized and forced through the check valve into the pipeline causing air related problems. All vertical pumps should have an air valve installed just upstream of the check valve.

## WELL SERVICE AIR VALVE OPERATION

Well Service Air Valves mounted on the pump discharge pipe, upstream of the check valve, are designed to vent the air before the check valve is pushed open by the pump pressure. Also, when the pump stops, the Well Service Air Valve will reopen and admit air into the pump column to prevent the formation of a vacuum. When the valve is closed, the float is held upward tight against the resilient seat. The seat is contained in a precision register in the valve cover and held in place with a baffle assembly which also guides the float.

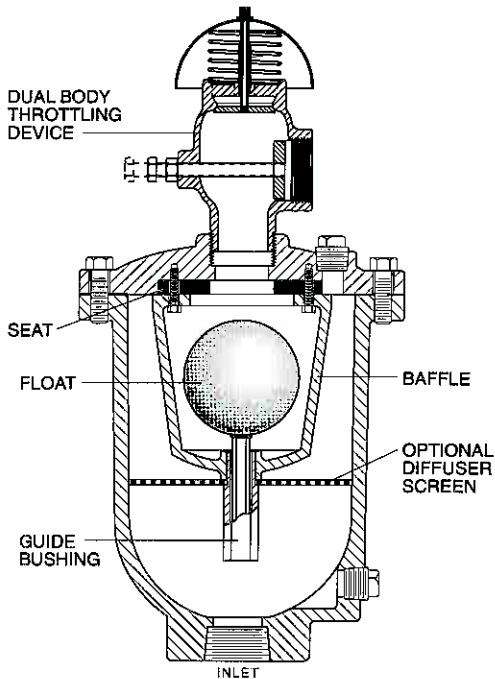

1"-3" Well Service Air Valve

Pump service is a severe application for air valves because when the pump is started, it runs for the first few seconds against little or no head. Hence, the actual flow rate is often as high as 150% of the normal flow rate while the air is being vented. Also, because of the high dynamics involved, the air discharge is sonic and water often bypasses the rapidly closing air valve. Therefore, the valve outlet should be piped back to the wet well or an open drain.

Not only is the flow high, but there is a moment of time when the last of the air is vented and the water reaches the air valve with virtually no place to go. It simultaneously crashes into the closing air valve and the closed check valve disc. If the water velocity striking the closed check valve is high, surges will occur in the pump column and discharge pipe.

Throttling devices are provided to control the rate of air release, especially with slow opening control check valves. Surges can also be minimized by using soft-start pump motor controls or fast opening check valves such as Swing-Flex® or Tilted Disc® check valves.

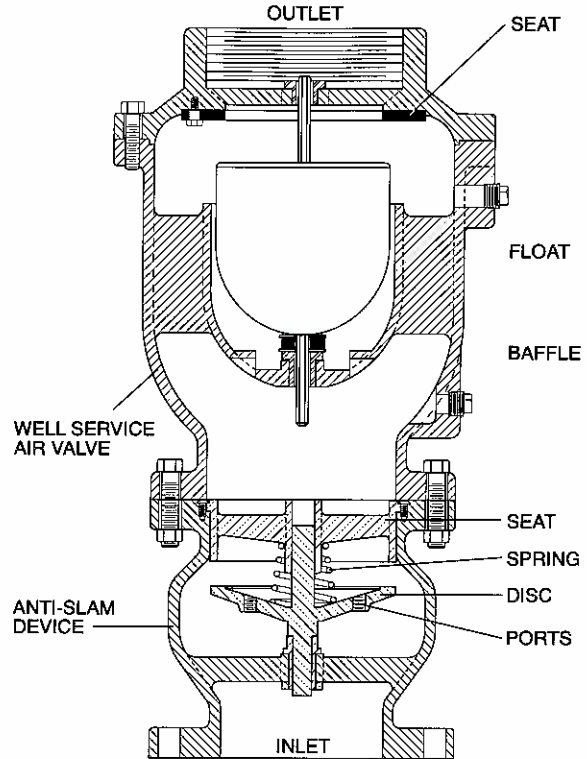

4" Well Service Air Valve

## ANTI-SLAM DEVICES

The purpose of an Anti-Slam Device is to protect the Well Service Air Valve from pressure surges while allowing the valve to vent. It is mounted on the inlet of the valve as shown above. When water reaches the Anti-Slam Device, the disc closes quickly controlling the rate at which fluid enters the valve while allowing air to be continuously discharged.

The disc contains ports which allow water to flow through the anti slam device when closed to fill the air valve with water at a controlled rate. The flow area of the anti-slam disc ports is typically about 5% of the full port area and is adjustable by adding threaded plugs to the ports. If the Well Service Air Valve closes too rapidly during pump start up, then one of the ports should be plugged until the valve closure is smooth.

Anti-Slam Devices are standard on 4" and larger valves and optional on smaller valves where surges are not typically as high.

## DUAL PORT THROTTLING DEVICES

The purpose of the Throttling Device is slow the release of air and thereby slow the rise of water in the pump column. Dual Port Throttling Devices are standard on Well Service Valves sizes 1/2" to 3" and optional on larger valves when valve closure is rapid.

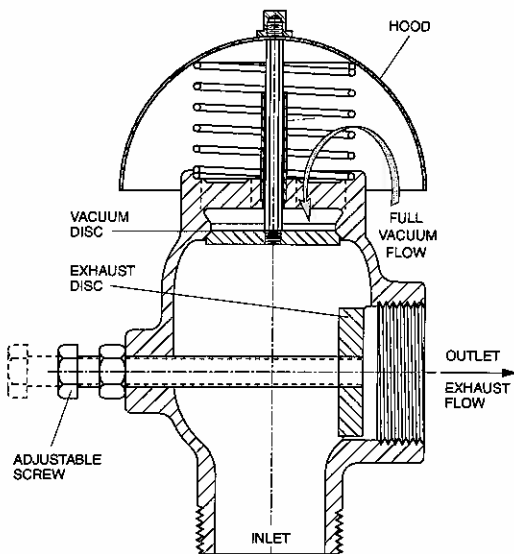

**Dual-Port Throttling Device**

A Throttling device has an exhaust disc which is typically adjusted between 5% and 30% open to control the venting rate. The valve needs to be set in the field and tuned to the operation of the pump. The Throttling Device should be opened just enough so that all of the air is discharged before the check valve opens. Opening the throttling device further will increase the pressure surge in the pump column.

The Throttling Device also allows air to reenter the pump column when the pump is stopped to prevent a vacuum. A vacuum can damage the seals in the pump or cause pump damage if it is restarted while the water is still dropping in the well. To provide positive assurance against a vacuum, a dual ported throttling device is needed where the vacuum port is separate from the exhaust port. If there is a common outlet, then the vacuum flow will be greatly restricted through the air discharge pipe. The vacuum flow could also be stopped or contaminated if the air discharge pipe becomes submerged in a drain or a high wet well level. A Dual-Port Throttling Device should be used at all times.

## APPLICATION CRITERIA

The general operating parameters for the Well Service Air Valves are summarized in the table below. A comprehensive presentation of features and dimensions is presented in Val-Matic Bulletin 100WS.

### STANDARD OPERATING PARAMETERS Valve Series 100WS

PARAMETER	TYP RANGE OF USE
Size Range	1/2" - 12"
CWP Ratings	150 and 300 psig
Max Temperature	250°F
Orientation	Vertical
Connection	NPT or Flanged (≥ 4")

The valve is versatile and can be used in more demanding applications with the use of special materials of construction upon request. Fast starting pumps will require a Dual Ported Throttling Device, especially when the check valve is a slow opening control valve.

## SIZING OF WELL SERVICE AIR VALVES

Traditionally, valves used for well service applications were sized very conservatively at a differential pressure of 0.5 psi so that the water velocity entering the valve was not excessive. When using a Dual Port Throttling Device or Anti-Slam Device, a differential pressure of 2 psi is used as shown in the table below.

Well Service Air Valve Sizing			
SIZE	PUMP GPM (at 0 head)	150 psi Model No.	300 psi Model No.
1/2"	0-350	100T	
1"	351-1350	101T	
2"	1351-4000	102T	
3"	4001-7000	103T	
4"	7001-11,000	104WS	154WS
6"	11,001-24,000	106WS	156WS
8"	24,001-50,000	108WS	158WS
10"	50,001-70,000	110WS	160WS
12"	70,001-110,000	112WS	162WS

(T = Throttling Device, WS = Anti-Slam Device)

## WELL SERVICE AIR RELEASE VALVE FOR POWER CHECK VALVES

A different type of air valve can be used with vertical pumps when the check valve is a slow opening control valve or power actuated butterfly valve: a Well Service Air Release Valve equipped with a special vacuum port in the cover.

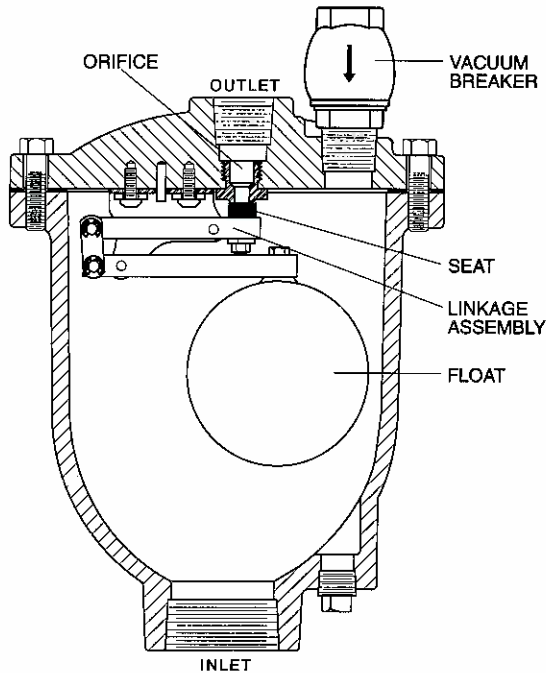

**Well Service Air Release Valve**

When using an Air Release Valve, the control valve opening is delayed until the air is vented through the Air Release Valve. An Air Release Valve can vent air at very high pressures, even up to the shut off pressure of the pump. The valve orifice will be sized to discharge the air so that the water in the pump column rises at a rate less than 2 ft/sec.

The flow rate for sizing can be calculated as follows:

$$SCFM = \frac{\pi L D^2 (P+14.7)}{4 v (14.7)}$$

where:

- L = distance from top of water to check valve, ft.
- D = column diameter, ft.
- P = pipeline static pressure, psig
- v = water rise velocity  
= 2 ft/sec

For example, a 1 ft. diameter by 100 ft. long pipe at 60 psig will need to discharge 64 SCFM. Using the air release valve capacity graph shown in Bulletin No. 15, a 3/8 in. orifice should be selected.

## APPLICATION CRITERIA

The general operating parameters for Air Release Valves are summarized in the table below. A comprehensive presentation of features and dimensions is presented in Val-Matic Drawing VM-45WS.

### STANDARD OPERATING PARAMETERS Valve Series 45WS

PARAMETER	TYP RANGE OF USE
Size Range	2" or 3"
Vacuum Breaker	1"
CWP Ratings	150, 300, and 400 psig
Max Temperature	250°F
Orientation	Vertical
Connection	NPT

## SUMMARY

General recommendations for Well Service Air Valves are based on the following parameters:

- Type of Pump:** A horizontal pump with positive suction pressure does not need a Well Service Air Valve. However, an Air Release Valve is often installed on the top of the volute to automatically keep the pump free of air. Vertical pumps require Air Valves or air will be forced into the pipeline.
- Type of Check Valve:** Mechanical check valves such as Silent Check, Swing-Flex® or Tilted-Disc® Check Valves require a Well Service Air Valve. Power actuated Check Valves such as a control valve or butterfly valve may use either a Well Service Air/Vacuum Valve or a Well Service Air Release Valve.
- Sizing Pressure:** Well Service Air/Vacuum Valves are sized using a differential pressure of 2 psi. Well Service Air Release Valves are sized based on the equation above and the pump shut off pressure (i.e. 60 psi).
- Piping:** Well Service Air/Vacuum Valves should be piped back to the wet well or to an open drain.

Copyright © 2000. Val-Matic® Valve and Mfg. Corp.